

Goulds GIS Series

ISO
Frame &
Stub Shaft
Pumps



Goulds GIS Series

ISO End Suction Centrifugal Pump - Technical Sales Data

The ITT Goulds brand is renowned for manufacturing the highest quality pumping equipment utilizing the best engineering practices available worldwide. The Goulds GIS series back pull out, foot mounted centrifugal is no exception. The single stage end suction pump has been designed with the latest CAD (Computer Aided Design) and CFD (Computational Flow Design) aids and is in accordance with the international standard ISO2858. This highly efficient and flexible design makes the Goulds GIS pump ideal for a wide range of pumping applications, from Water Supply and Irrigation to Mining and Building Services.

Design Versions

The Goulds GIS series is manufactured in two designs; Frame Mount suitable for long coupled or belt driven motors and Stub Shaft suitable for direct attachment to 2 or 4 pole IEC frame motors. The standard horizontal configuration units have a vertical centreline discharge, however these models can also be mounted in a variety of different positions including horizontal discharge, with or without vertical mounting of the pump's bearing housing.

Pumped Liquid

Designed for non-combustible, low viscosity liquids, free of solids, abrasive materials and fibres. Various liquid chemical compositions are capable of being pumped through the use of a variety of construction materials and seal options (refer to materials listed below).

Construction materials

The Goulds GIS range comes standard with Cast Iron (GG25) casing wet end, Zinc Free bronze impeller and wear rings and a 420 Stainless Steel shaft. In order to suit a wider range of applications the GIS series of pumps is also available in the following materials:

- ♦ Ductile Iron
- ♦ 316 Stainless Steel
- ♦ Duplex Stainless Steel (1.4460)
- ♦ CD4MCu

Shaft

Enlarged shaft to minimize deflection, with tapered shaft keyed design ensuring positive locking when in operation and ease of impeller removal whilst servicing. Optional shaft materials are available on request.

Shaft Sealing

A wide range of sealing solutions are available for the Goulds GIS Series, the standard supply consists of a carbon rotating face and ceramic stationary face with nitrile elastomers. For alternative sealing requirements for hot or abrasive applications contact your authorized ITT Goulds distributor.

Bearing Housing & Bearings

Features incorporated into the design of the Goulds GIS bearing housing makes it robust, reliable and easy to service. Standard features include a removable bearing cap on the non-drive end and lip seals fitted to both drive and non-drive ends in order to minimize the ingress of foreign liquids and materials. Bearings are heavy duty NSK or approved equivalent bearings with pre-packed grease. Alternative bearing manufacturers and lubrication methods are available on request. The Stub Shaft version has a heavy-duty cast iron motor adaptor and robust drive shaft clamp for positive motor alignment and stability.

Operating Conditions

Flow:	Max. 900m ³ /hr
Head:	Max. 160 meters
Liquid Temp:	-15°C to 140°C (with hot water seal)
Max working pressure	160 metres

Please note that ITT, in the interests of product development, may alter technical specifications without notice

Goolds GIS Series

ISO End Suction Centrifugal Pump - Numbering System

Example Product Code

G I S 0 3 2 1 6 S N 1 1 F K 0

Sealing Options

0 = standard (carbon/ceremic/Nitrile)

P = Gland Packing (non abestos)

Motor KW Rating

- | | |
|-------------|-----------|
| H = 3 KW | P = 22 KW |
| J = 4 KW | Q = 30 KW |
| K = 5.5 KW | R = 37 KW |
| L = 7.5 KW | S = 45 KW |
| M = 11 KW | T = 55 KW |
| N = 15 KW | U = 75 KW |
| O = 18.5 KW | V = 90 KW |

For Frame Mounted Version, substitute the letters "FRME" in these position.

Motor Voltage Rating

- | | |
|----------------------------|------------------------|
| 50hz | 60hz |
| F - 380V/3Ph/50Hz | U - 220V/3Ph/60Hz |
| J - 380/415V, 3Ph/50Hz | V - 380V/3Ph/60Hz |
| L - 380/660V, 3Ph/50Hz | W - 220/380V, 3Ph/60Hz |
| N - 380-415/660V, 3Ph/50Hz | X - 230/460V, 3Ph/60Hz |

Enclosure & Protection

- 1 - IEC, IP54 TEFC(Standard)
- 2 - IEC, Increase Safety
- 3 - IEC, Frame Proof

For Stub shaft kits version, substitute the letters "KIT" in these position.

Motor Frequency & Pole Number

- | | |
|--------------|--------------|
| 1 - 50Hz, 2P | 5 - 60Hz, 2P |
| 2 - 50Hz, 4P | 6 - 60Hz, 4P |
| 3 - 50Hz, 6P | 7 - 60Hz, 6P |

Materials Option & Code

Code	Impeller	Casing	Shaft
ON	cast iron	cast iron	Stainless steel 420
SN	bronze	cast iron	Stainless steel 420
VN	stainless steel 304	cast iron	Stainless steel 420
WN	stainless steel 316	cast iron	Stainless steel 420
WW	stainless steel 316	stainless steel 316	Stainless steel 316

Nominal Impeller Diameter (x10)

e.g. 16 x 10 = 160mm

Discharge Port Diameter (mm)

e.g. 032 = 32 mm diameter

Product Line - ISO Series

Goolds ISO End Suction Centrifugal Pump

Goolds GIS Series

ISO End Suction Centrifugal Pump - 50HZ Performance Range

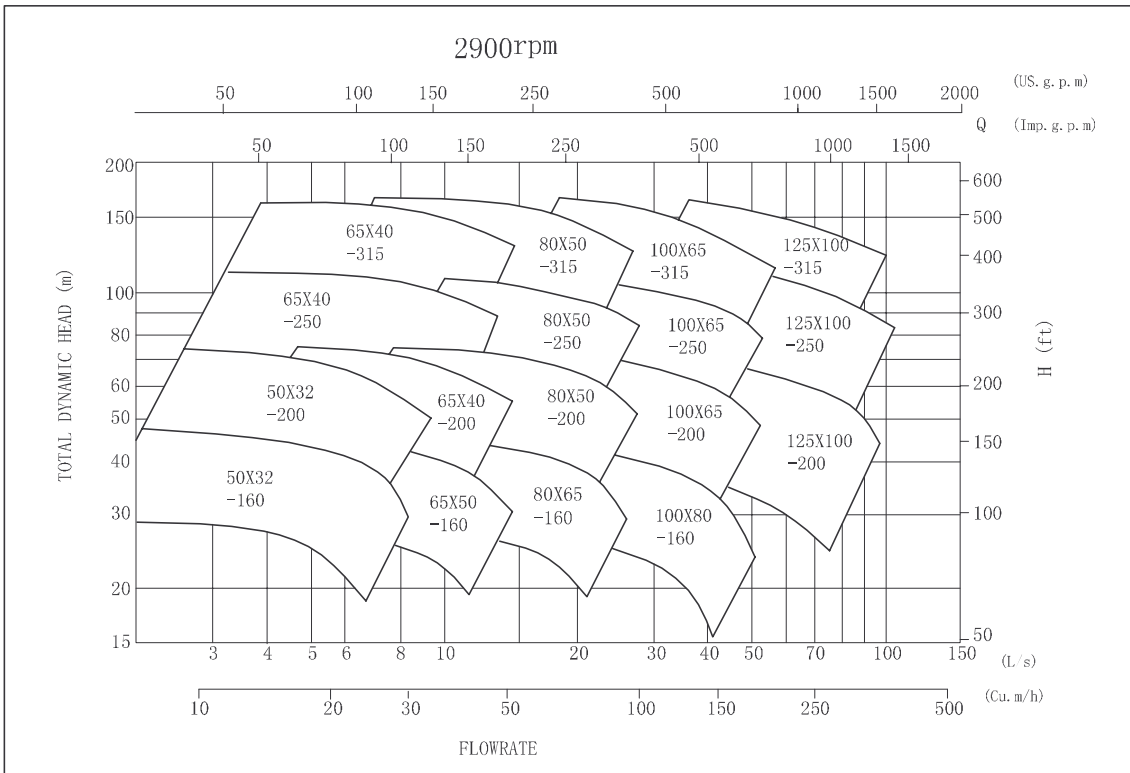
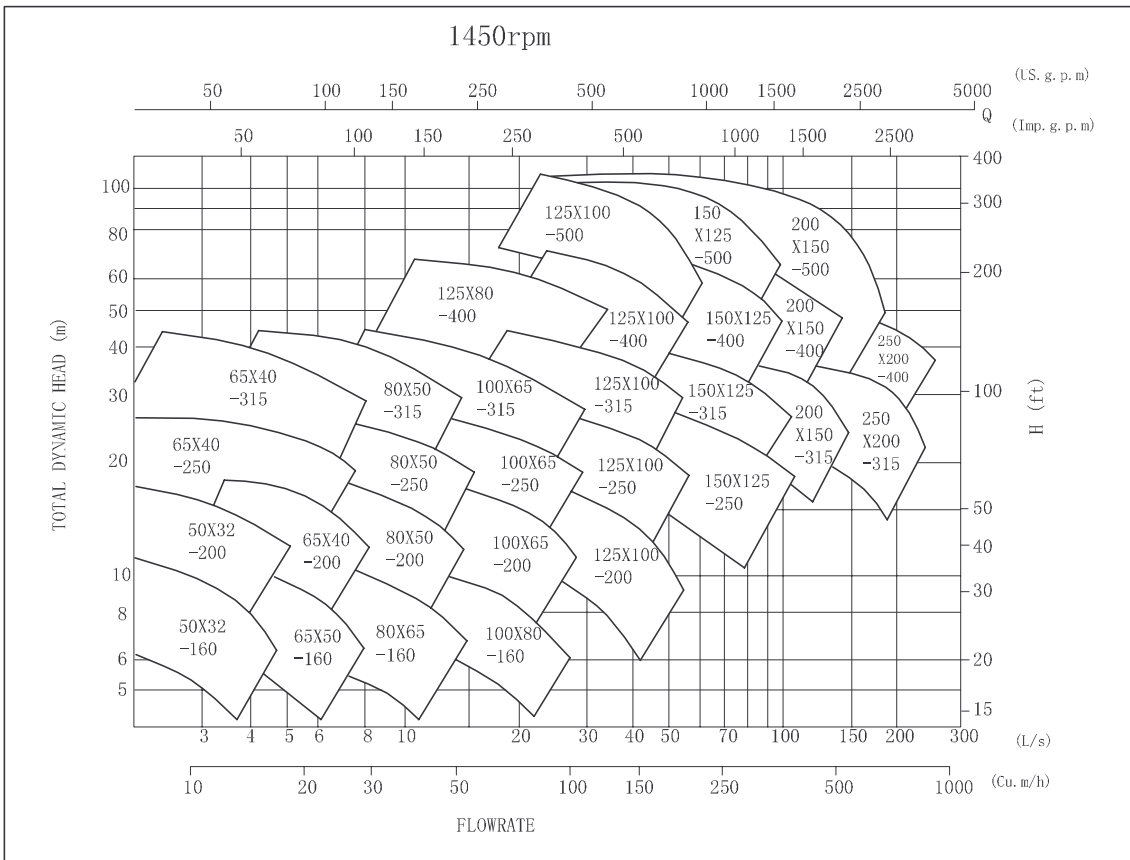

Pump performances comply to ISO2548, Class C standards

Goolds GIS Series

ISO End Suction Centrifugal Pump - 50x32-160 Performance Curve

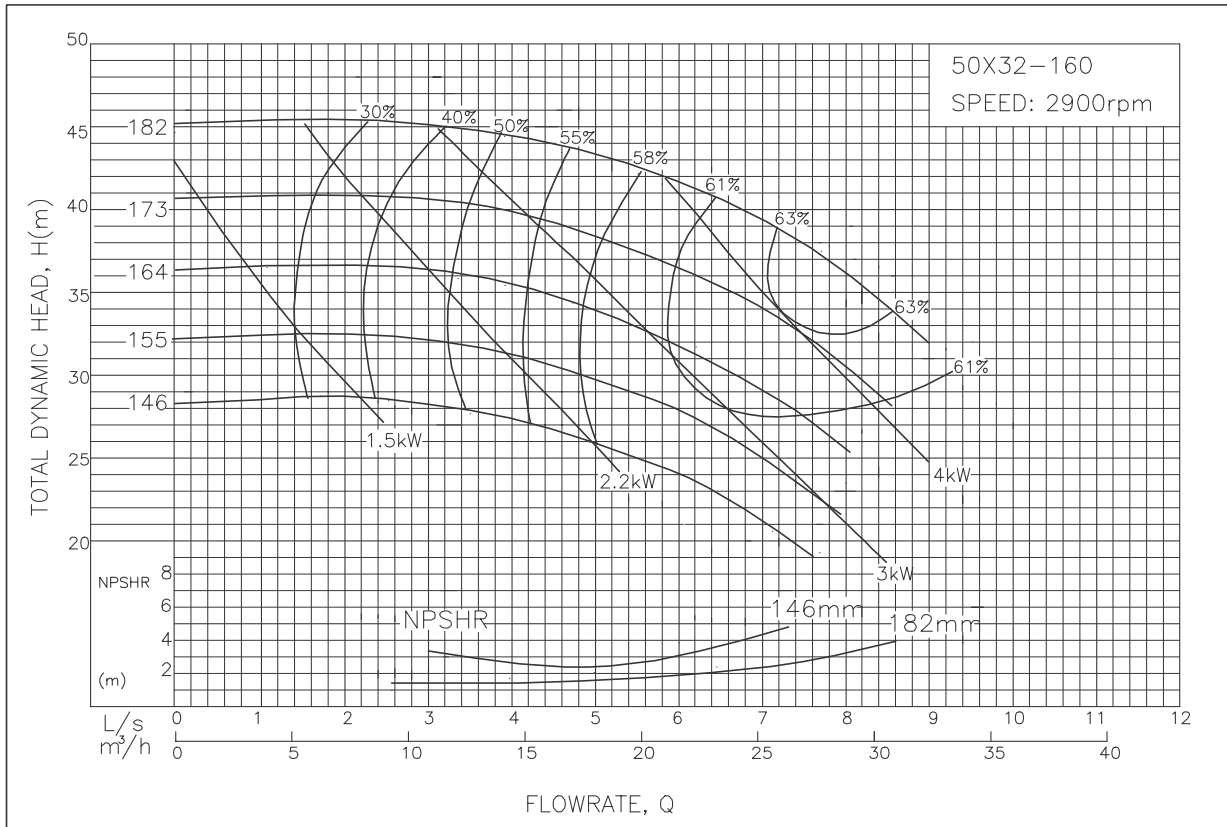
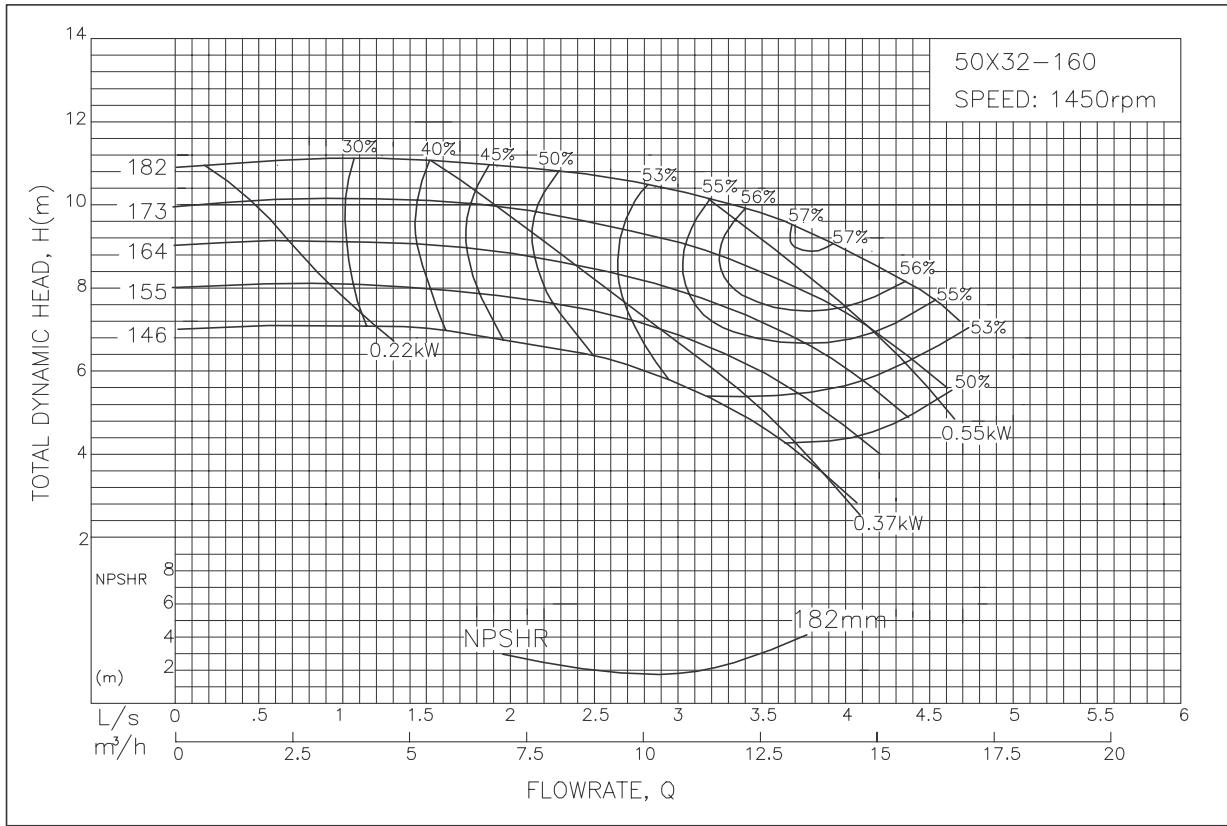

Performances for standard construction, clean cold water, efficiency correction for Stainless Steel construction 4%.

Goolds GIS Series

ISO End Suction Centrifugal Pump - 50x32-200 Performance Curve

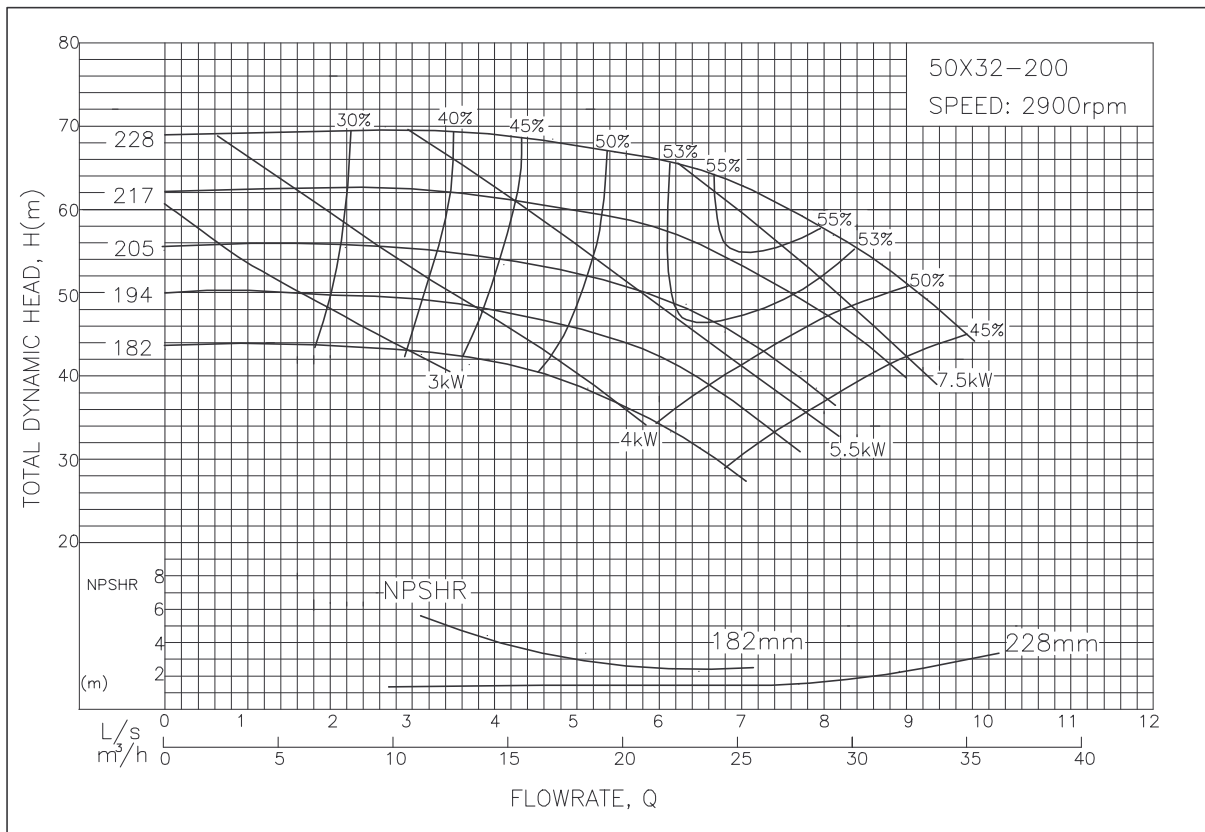
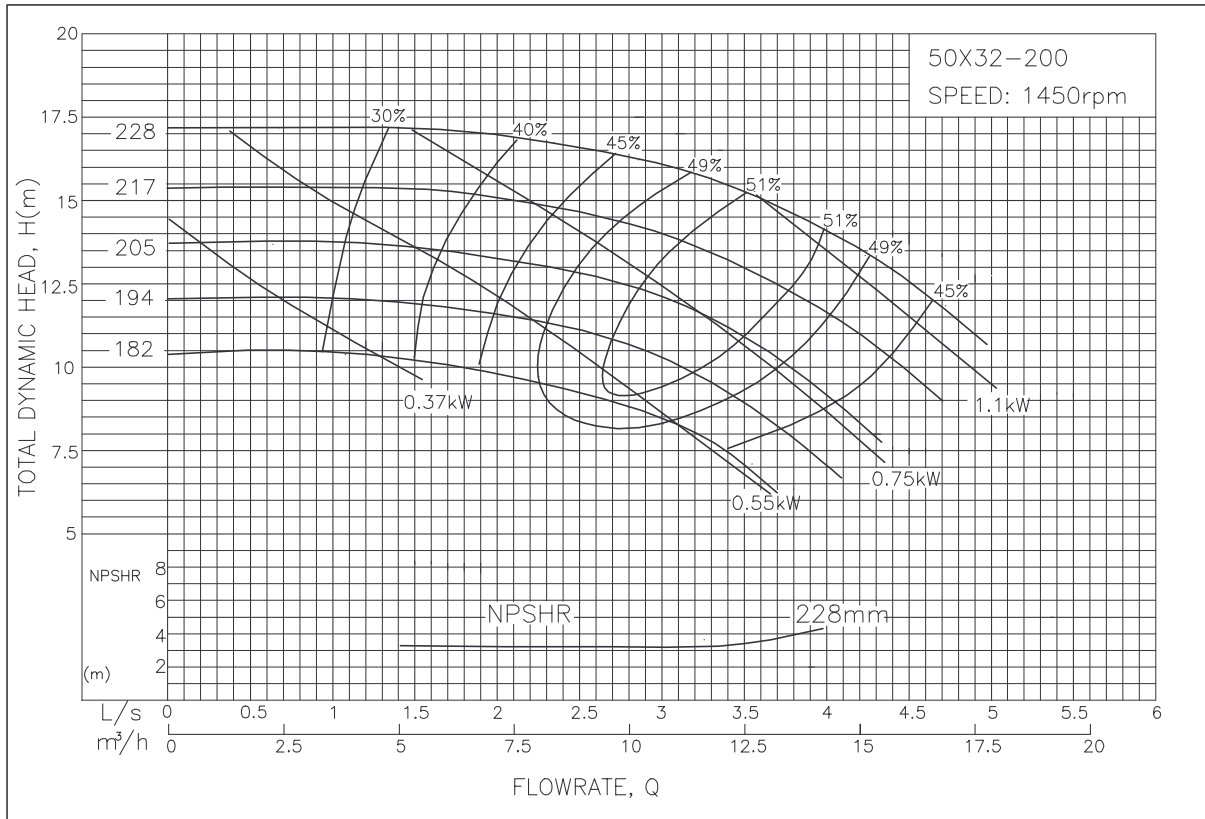

Performances for standard construction, clean cold water. Performance correction for Stainless Steel construction 4%.

Goolds GIS Series

ISO End Suction Centrifugal Pump - 65x40-200 Performance Curve

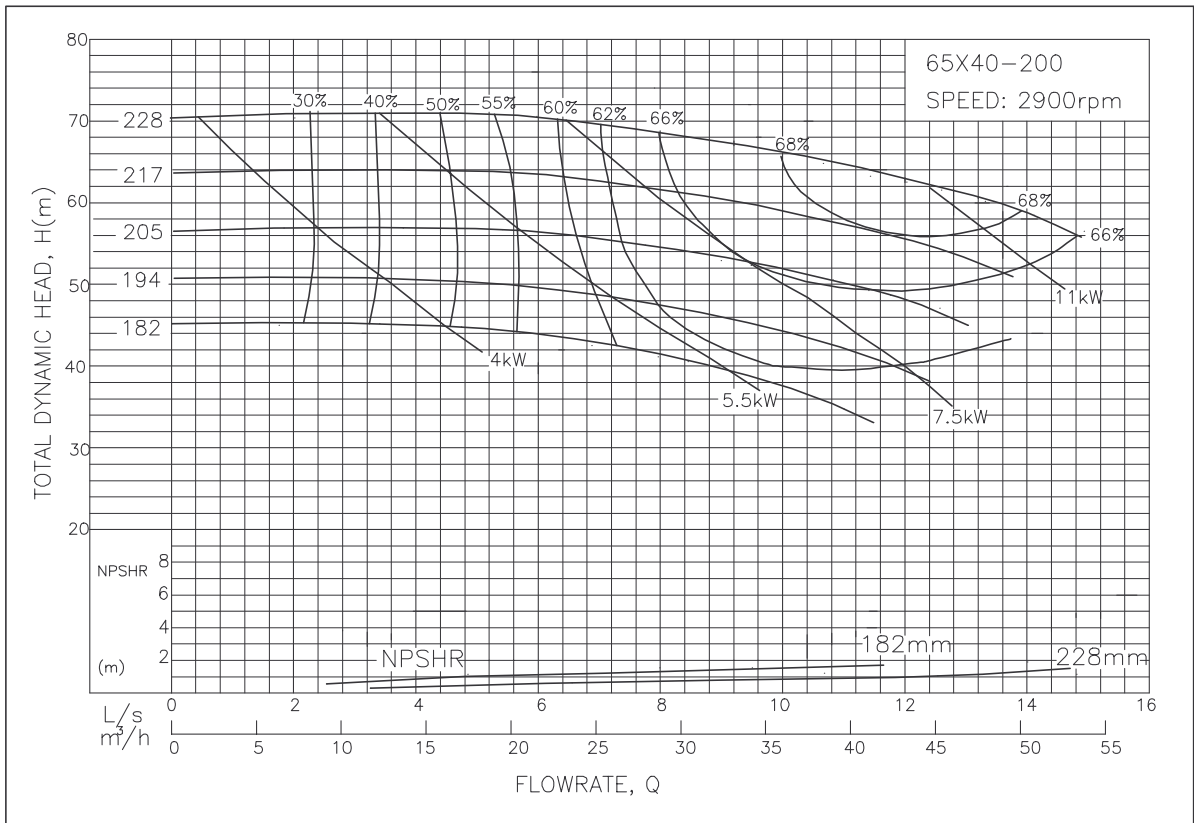
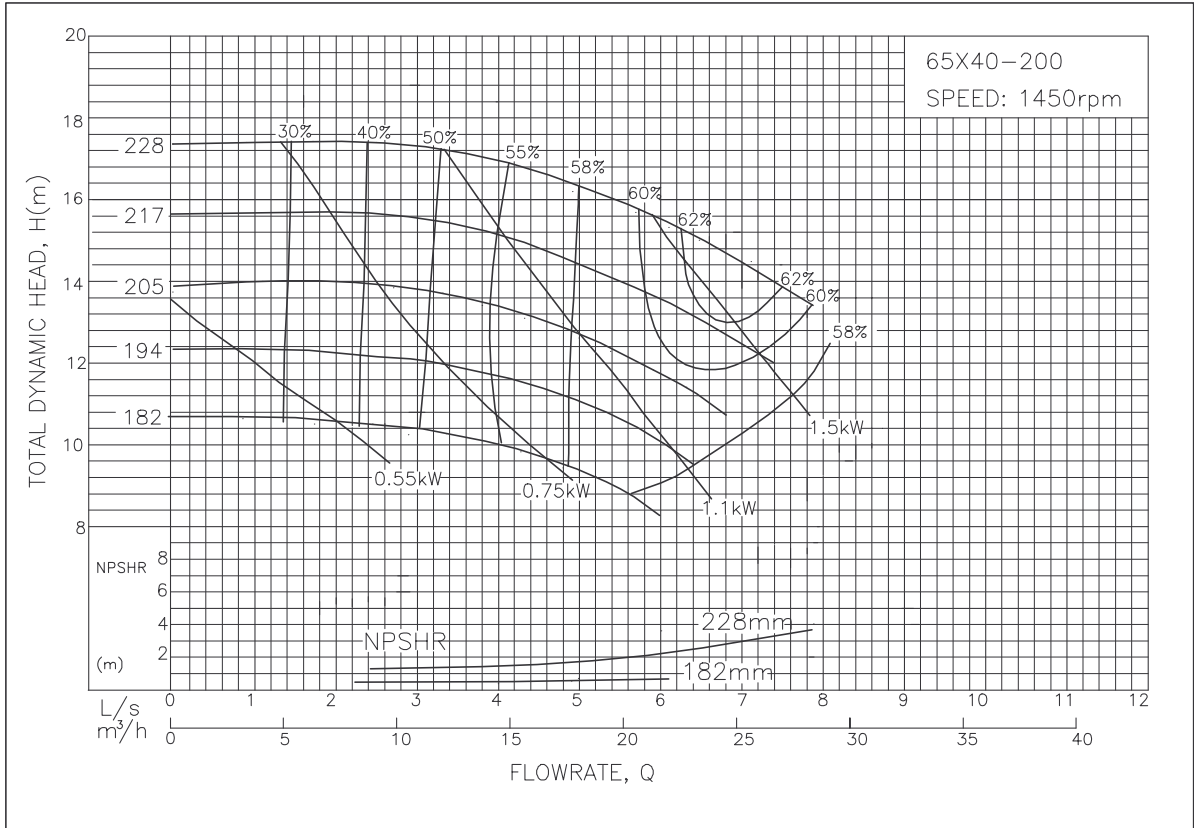

Performances for standard construction, clean cold water, efficiency correction for Stainless Steel construction 4%.

Goolds GIS Series

ISO End Suction Centrifugal Pump - 65x40-250 Performance Curve

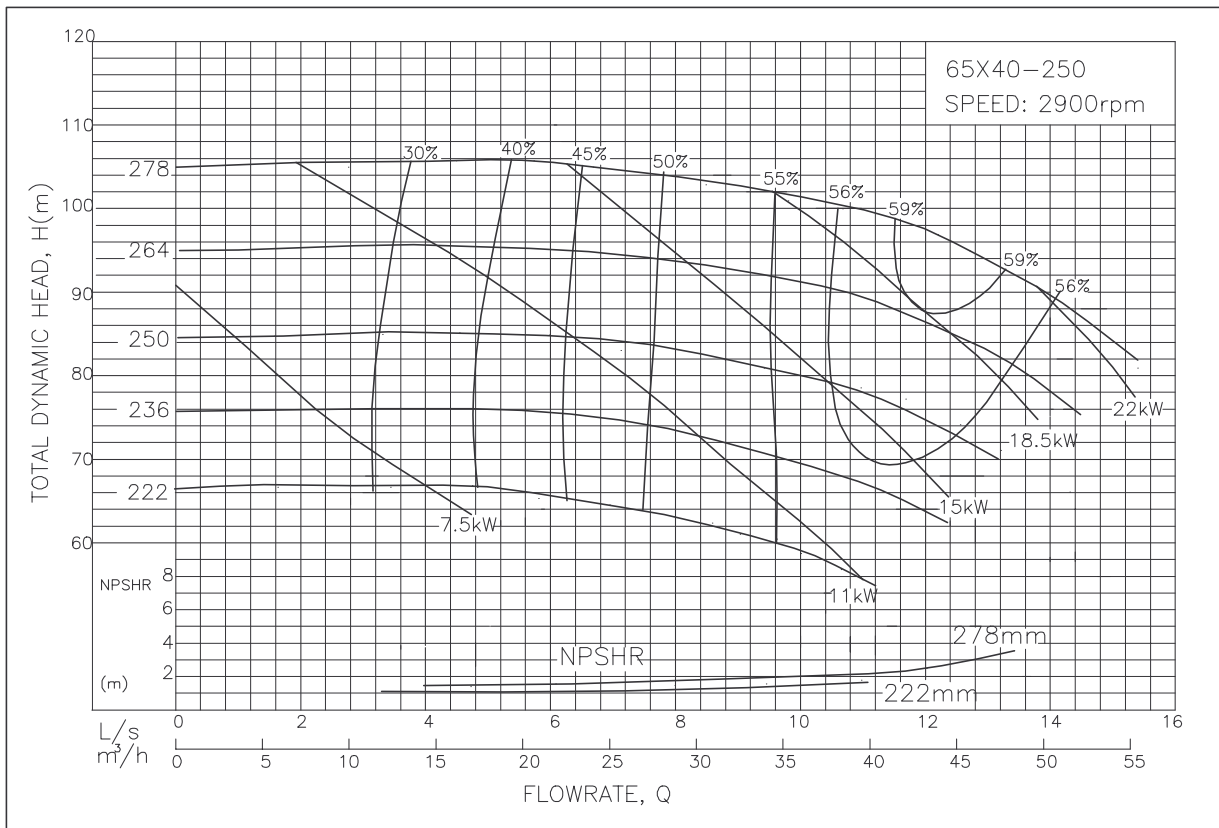
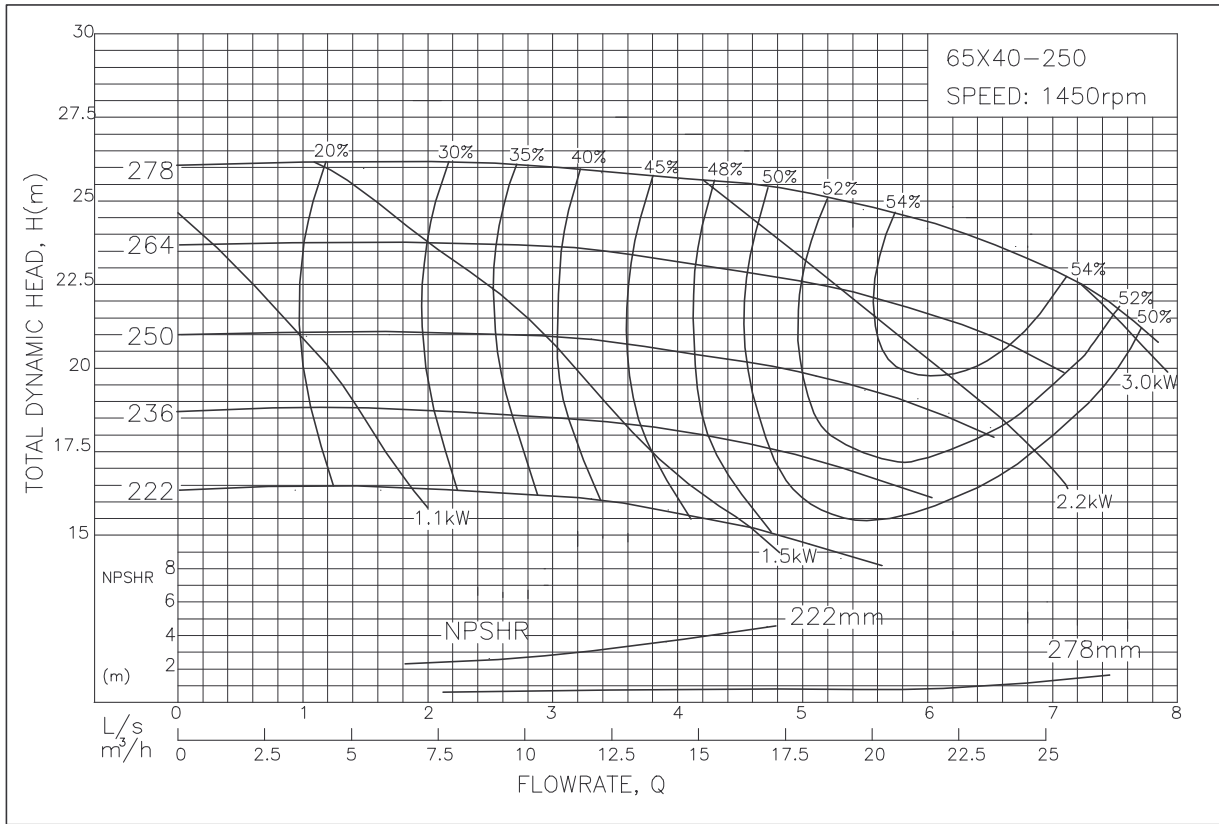

Performances for standard construction, clean cold water. Performance correction for Stainless Steel construction 4%.

Goolds GIS Series

ISO End Suction Centrifugal Pump - 65x40-315 Performance Curve

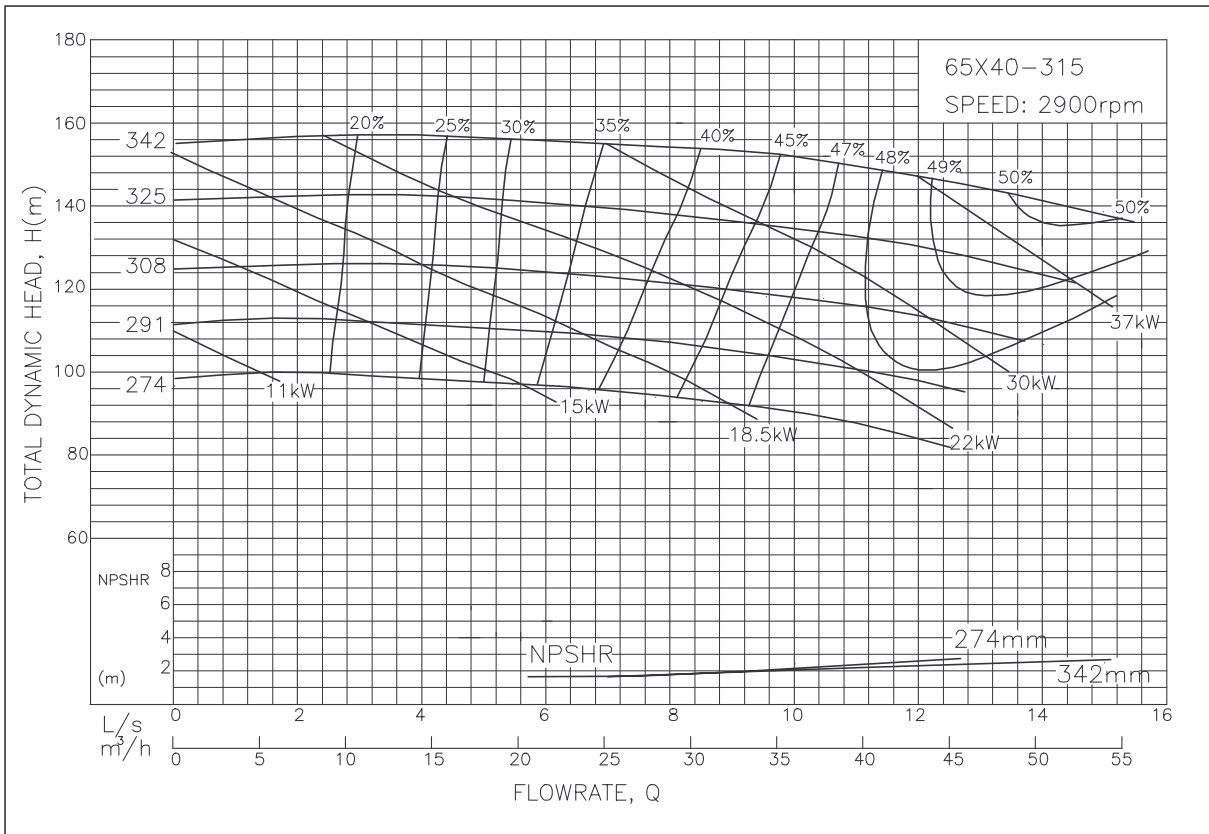
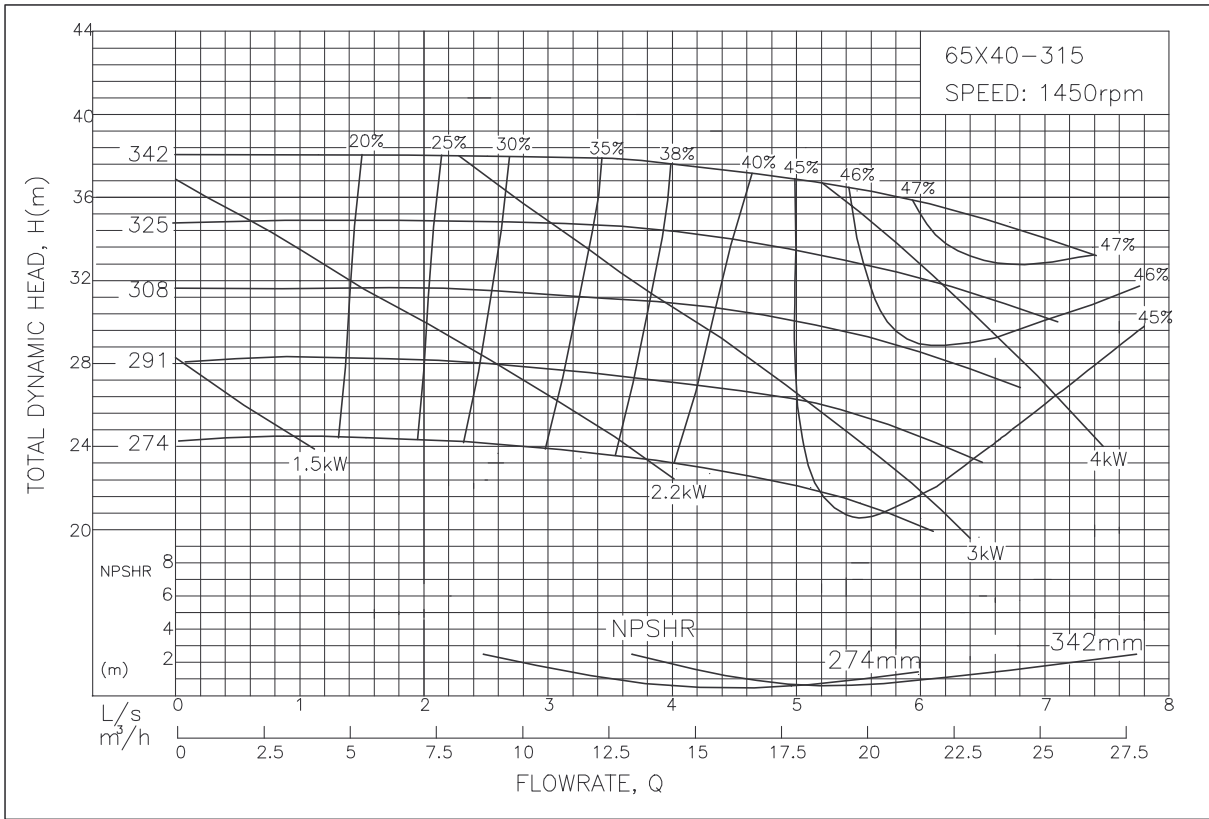

Performances for standard construction, clean cold water, efficiency correction for Stainless Steel construction 4%.

Goolds GIS Series

ISO End Suction Centrifugal Pump - 65x50-160 Performance Curve

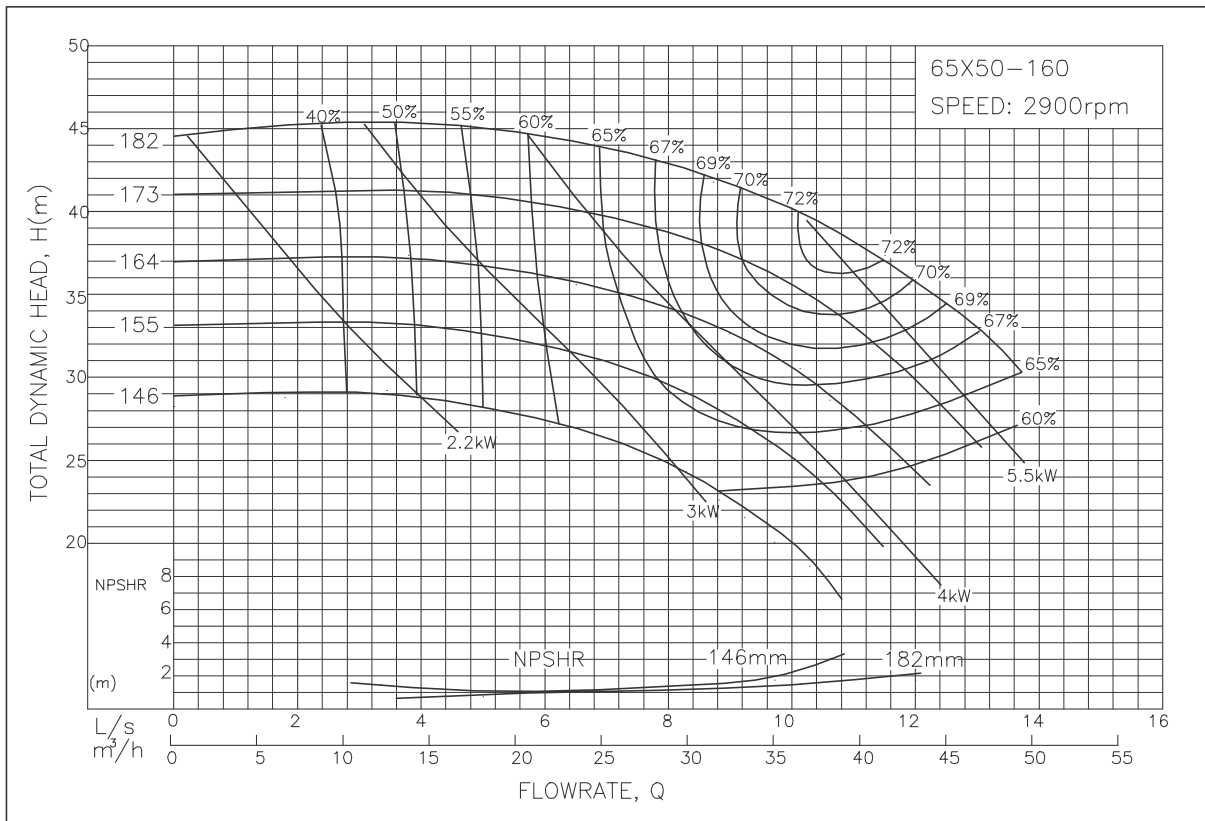
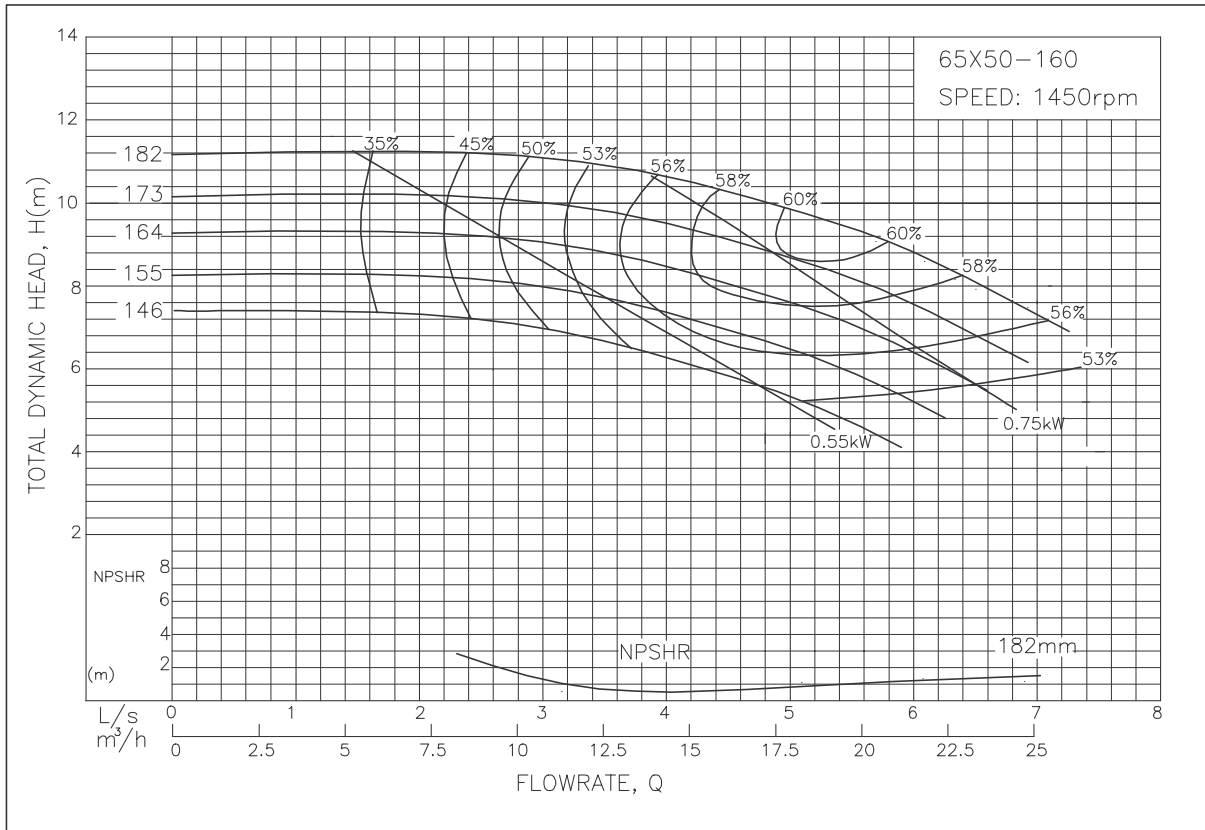

Performances for standard construction, clean cold water. Performance correction for Stainless Steel construction 4%.

Goolds GIS Series

ISO End Suction Centrifugal Pump - 80x50-200 Performance Curve

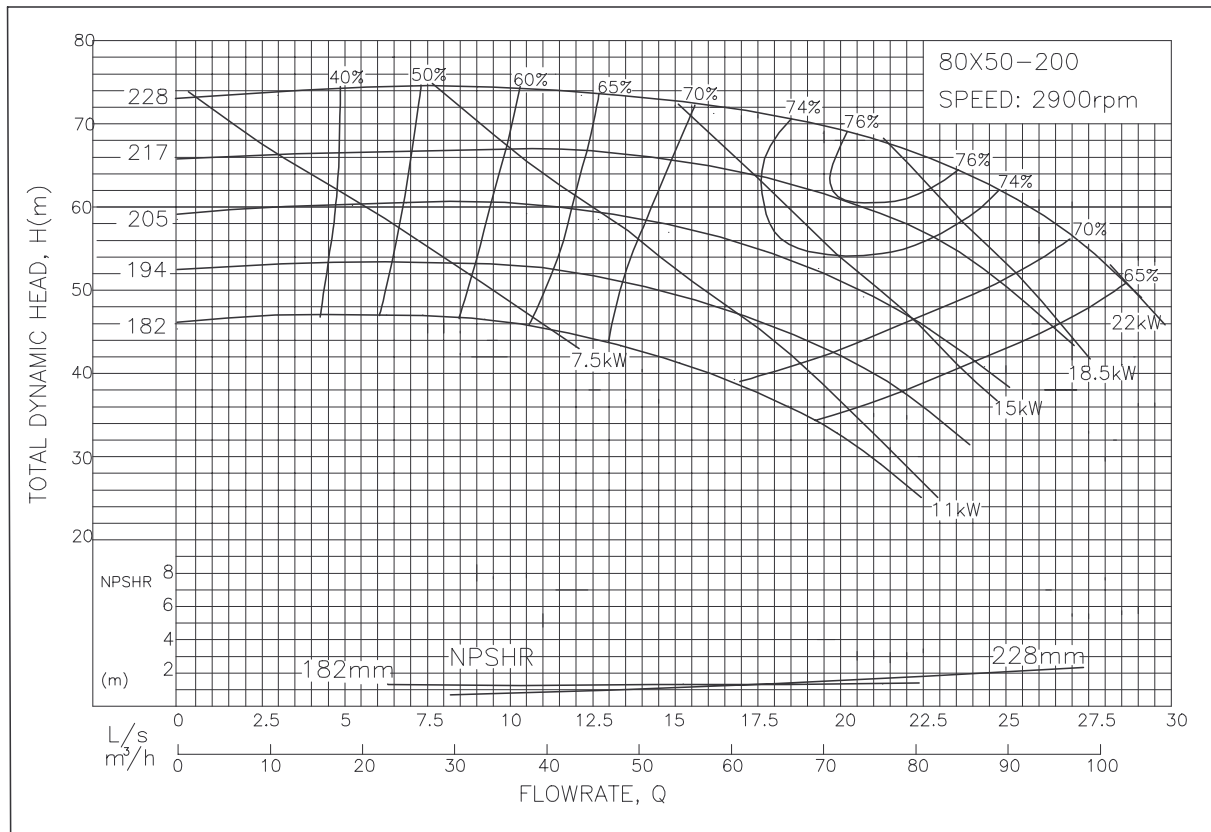
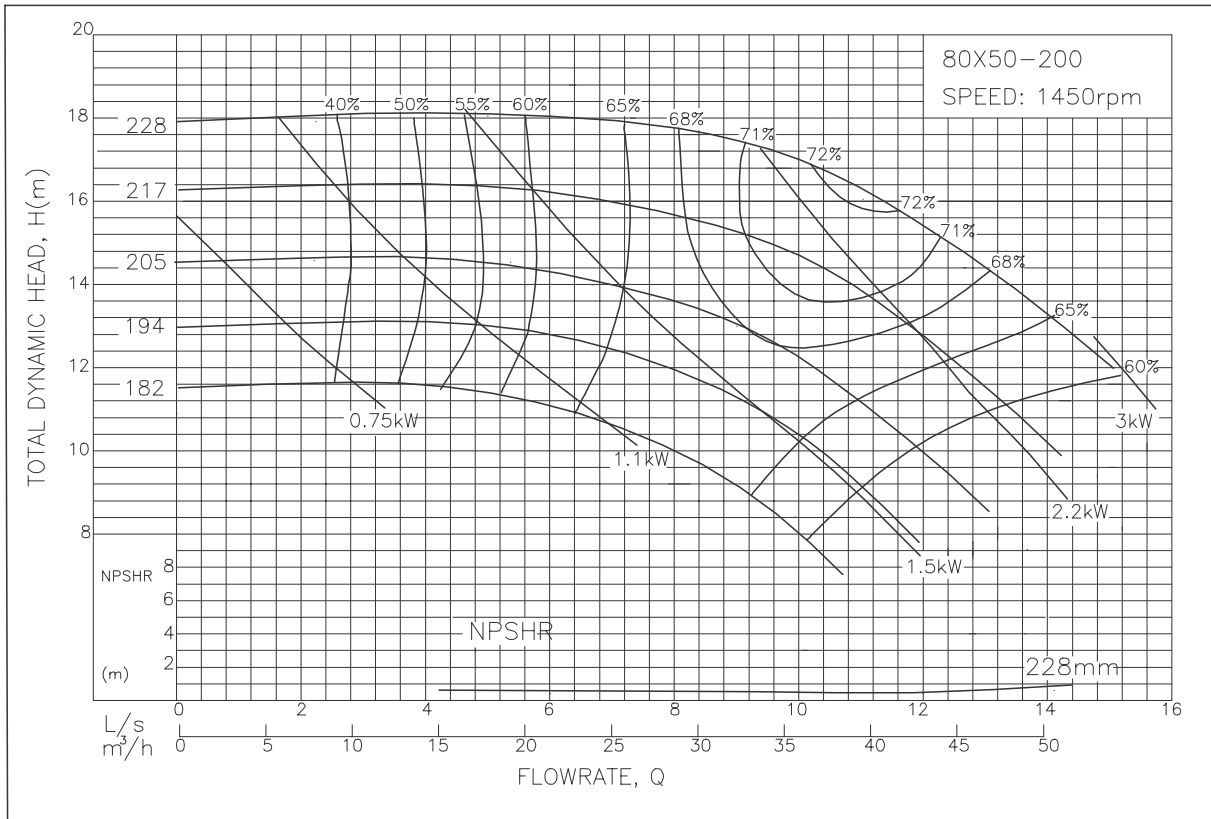

Performances for standard construction, clean cold water, efficiency correction for Stainless Steel construction 4%.

Goolds GIS Series

ISO End Suction Centrifugal Pump - 80x50-250 Performance Curve

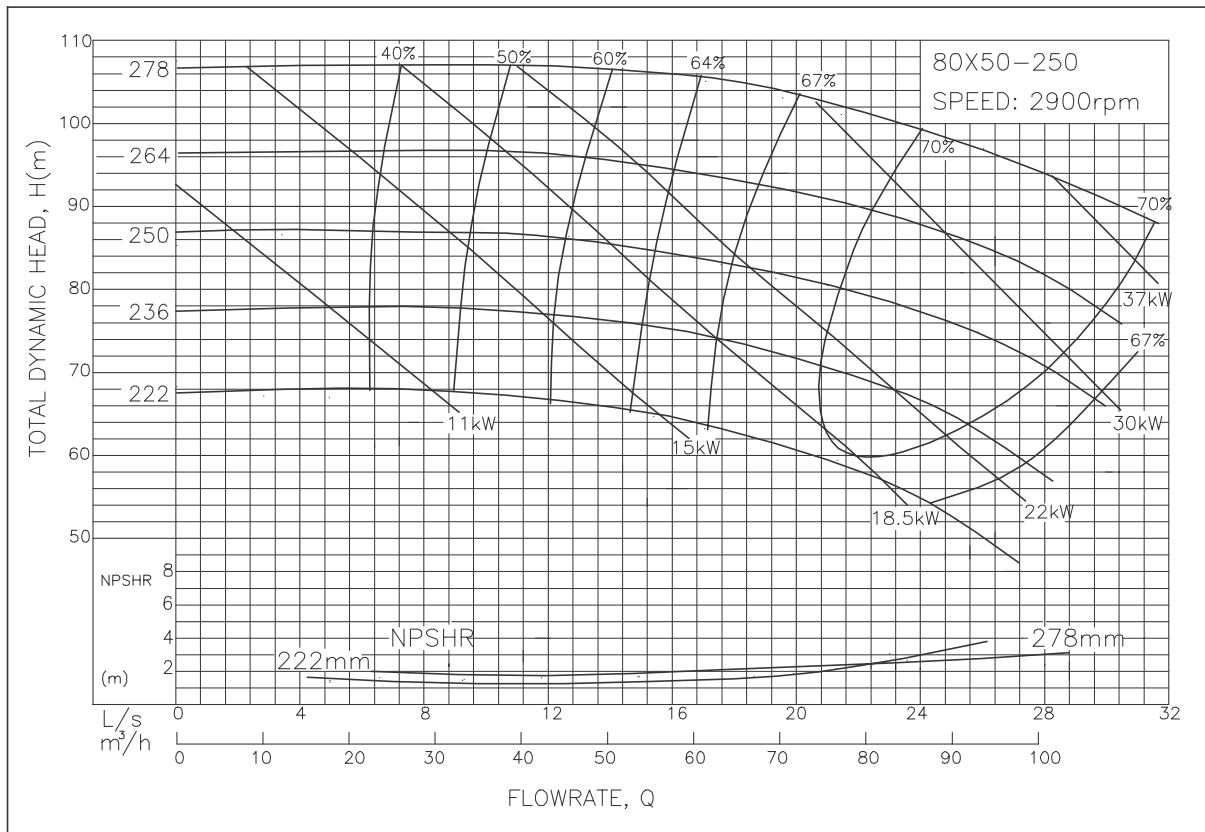
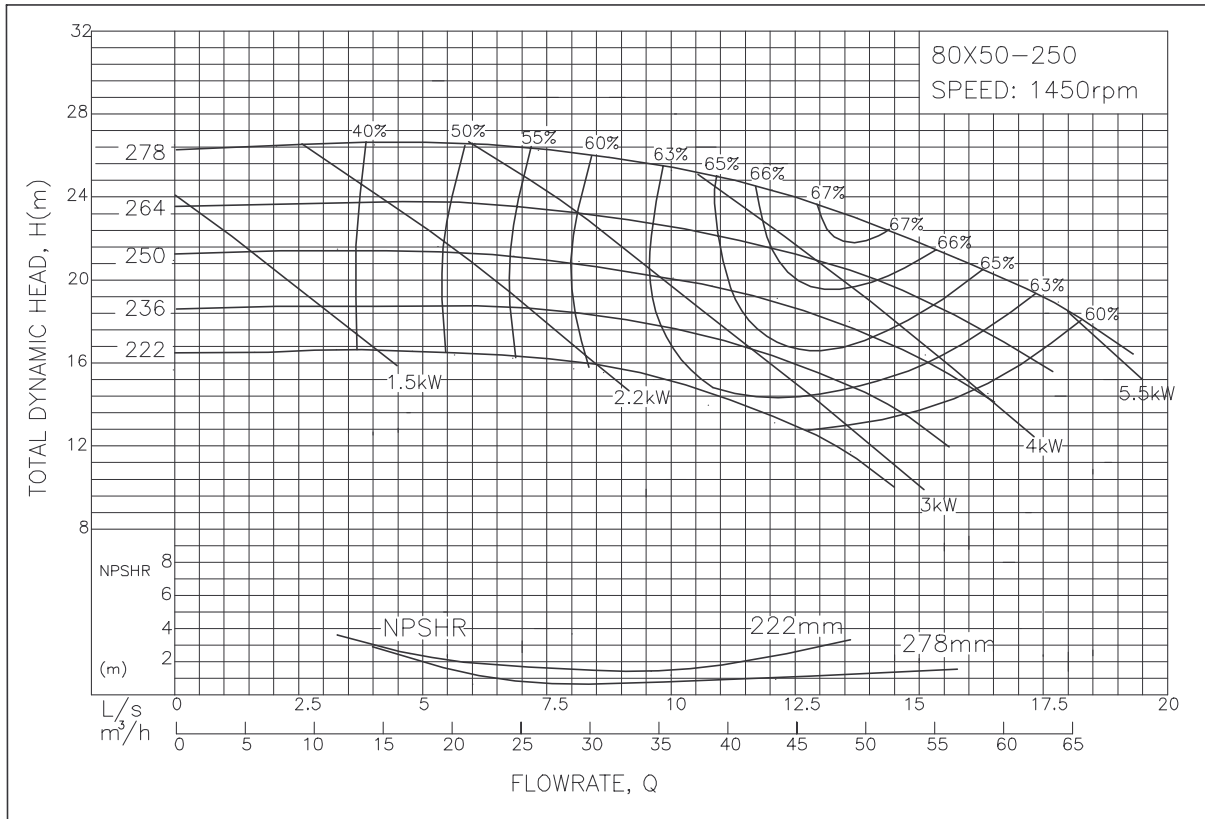

Performances for standard construction, clean cold water. Performance correction for Stainless Steel construction 4%.

Goolds GIS Series

ISO End Suction Centrifugal Pump - 80x50-315 Performance Curve

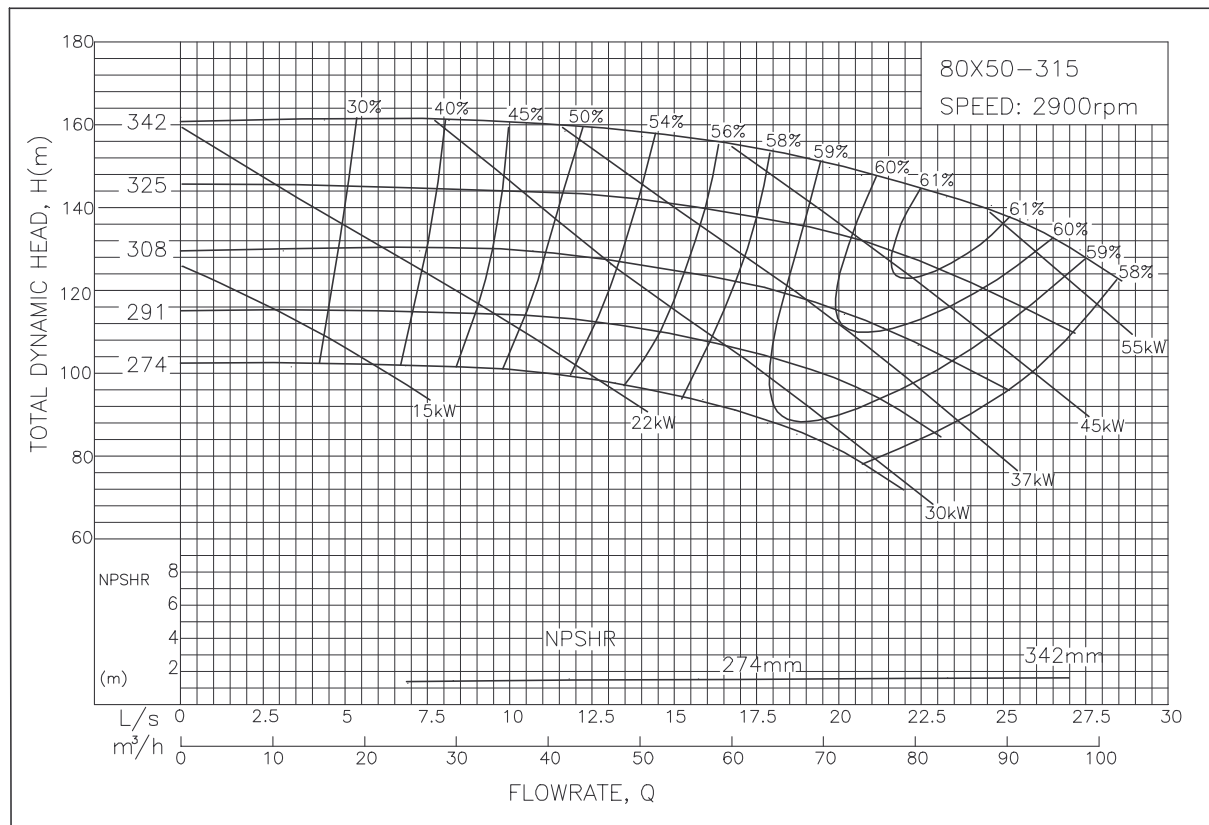
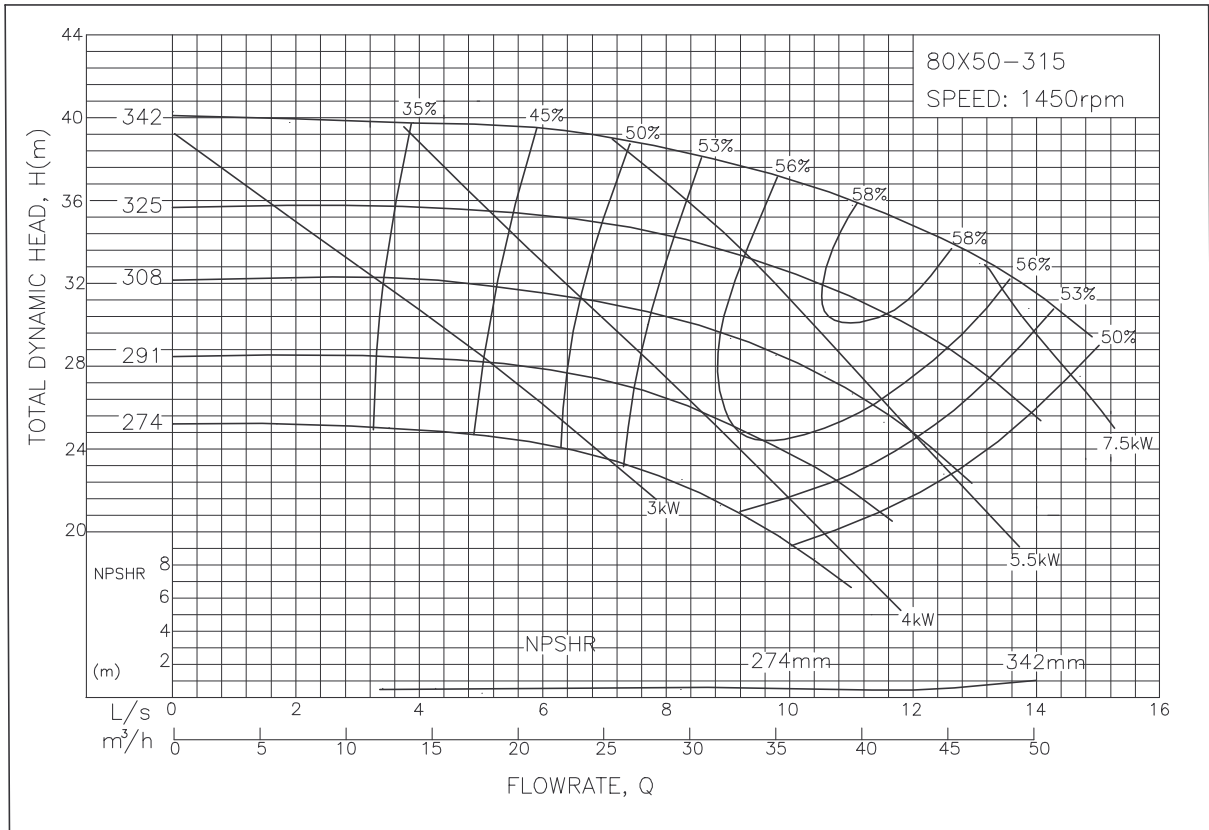

Performances for standard construction, clean cold water, efficiency correction for Stainless Steel construction 4%.

Goolds GIS Series

ISO End Suction Centrifugal Pump - 80x65-160 Performance Curve

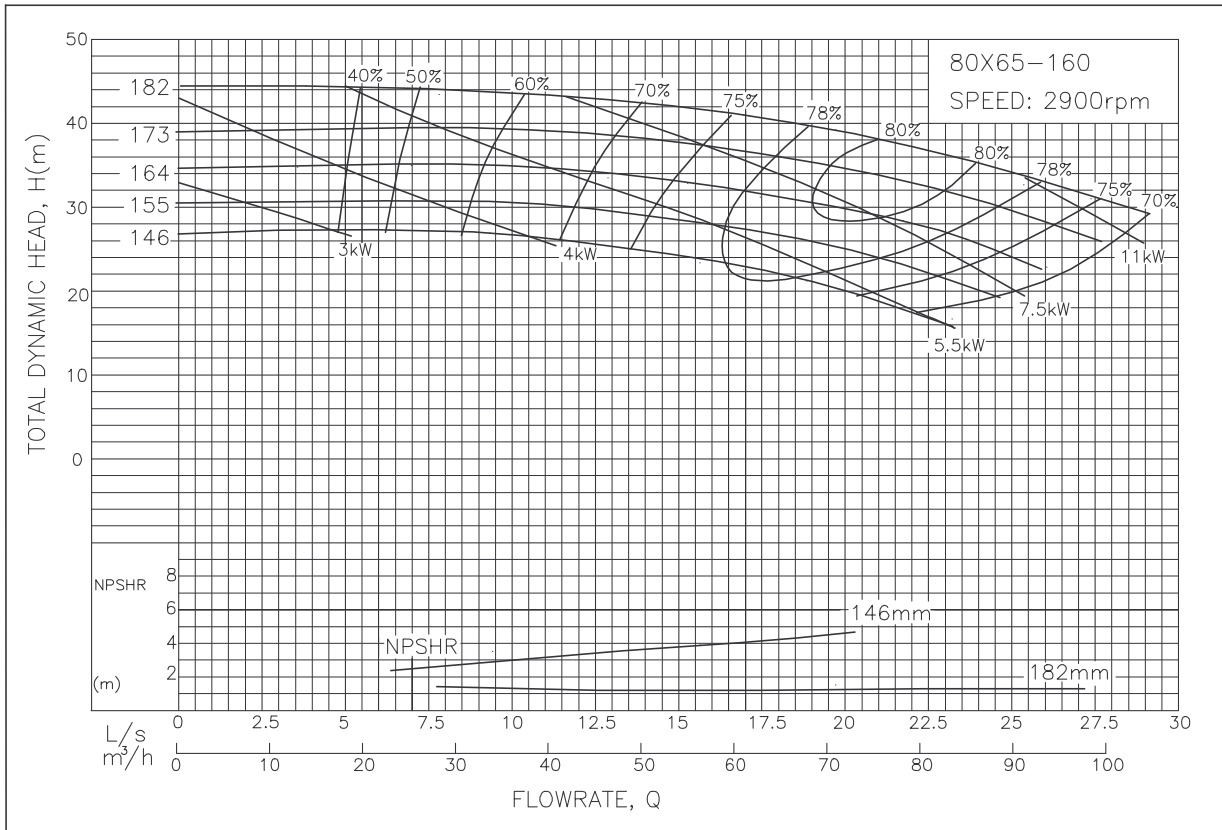
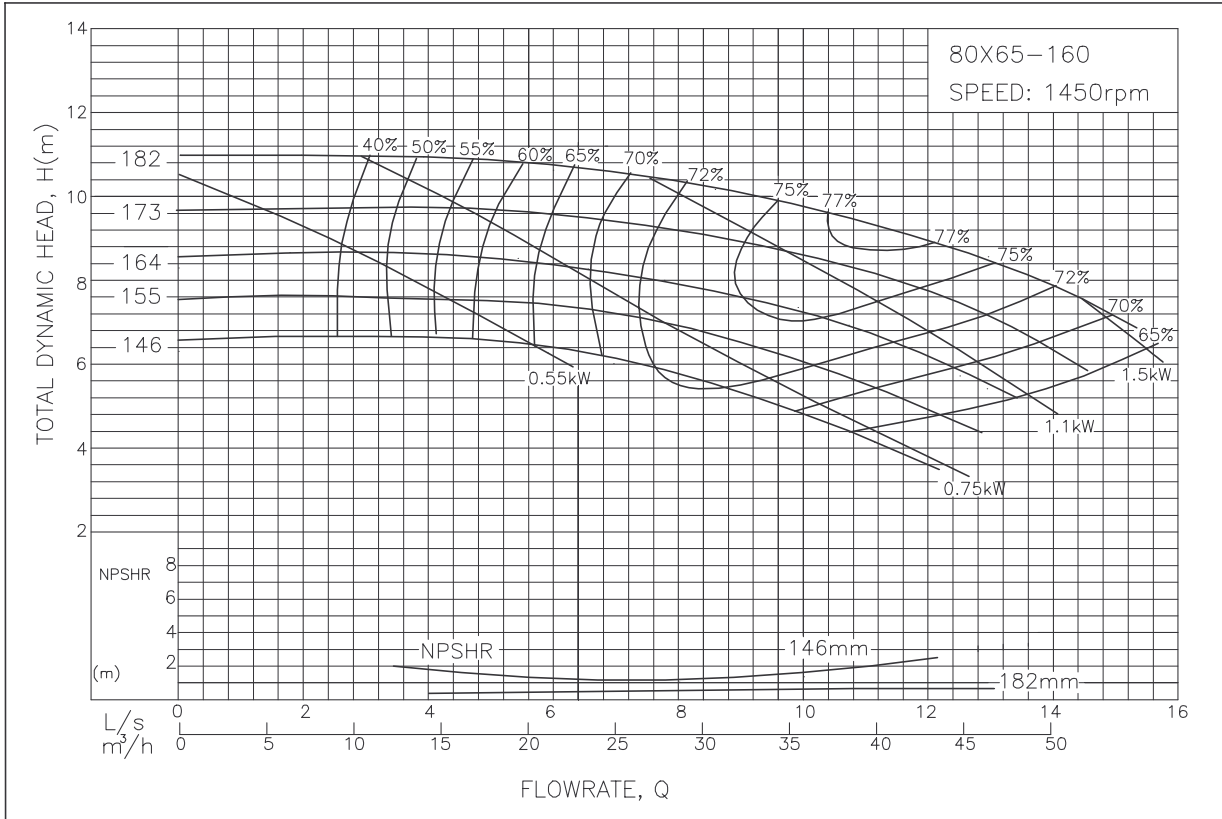

Performances for standard construction, clean cold water. Performance correction for Stainless Steel construction 4%.

Goolds GIS Series

ISO End Suction Centrifugal Pump - 100x65-200 Performance Curve

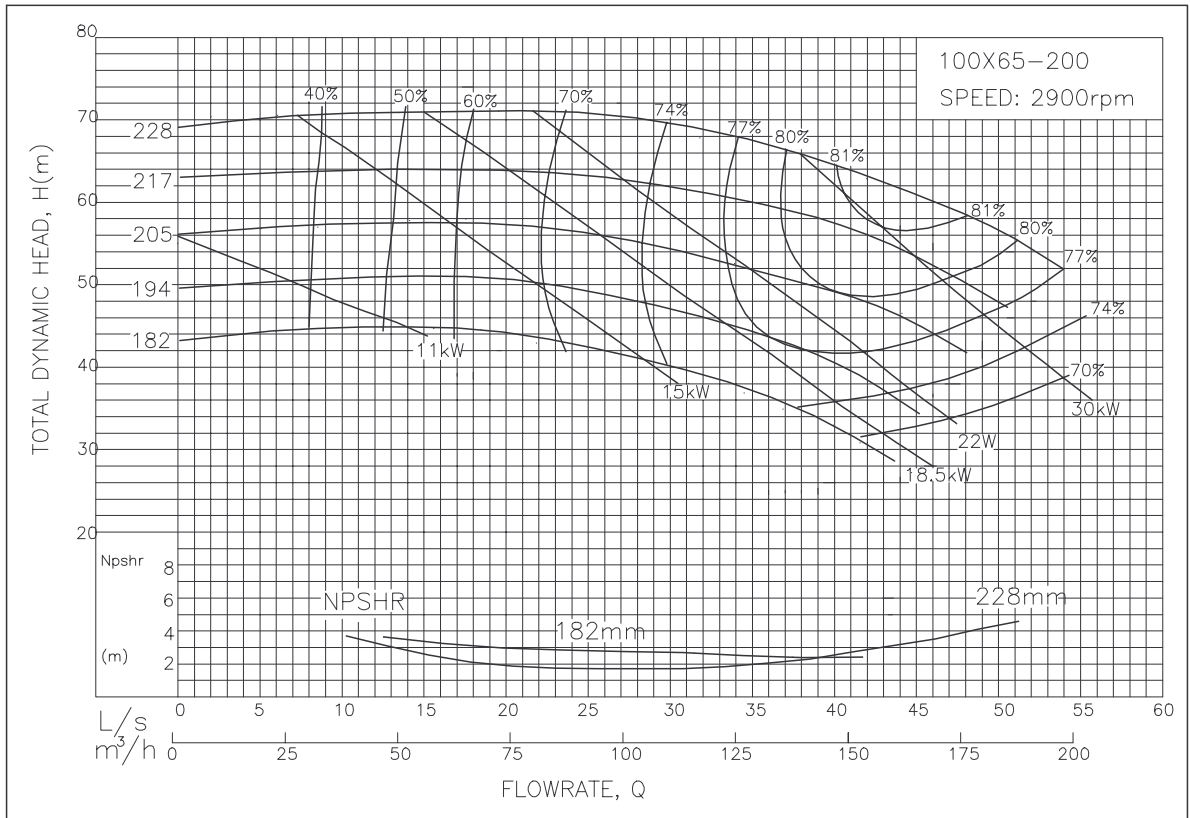
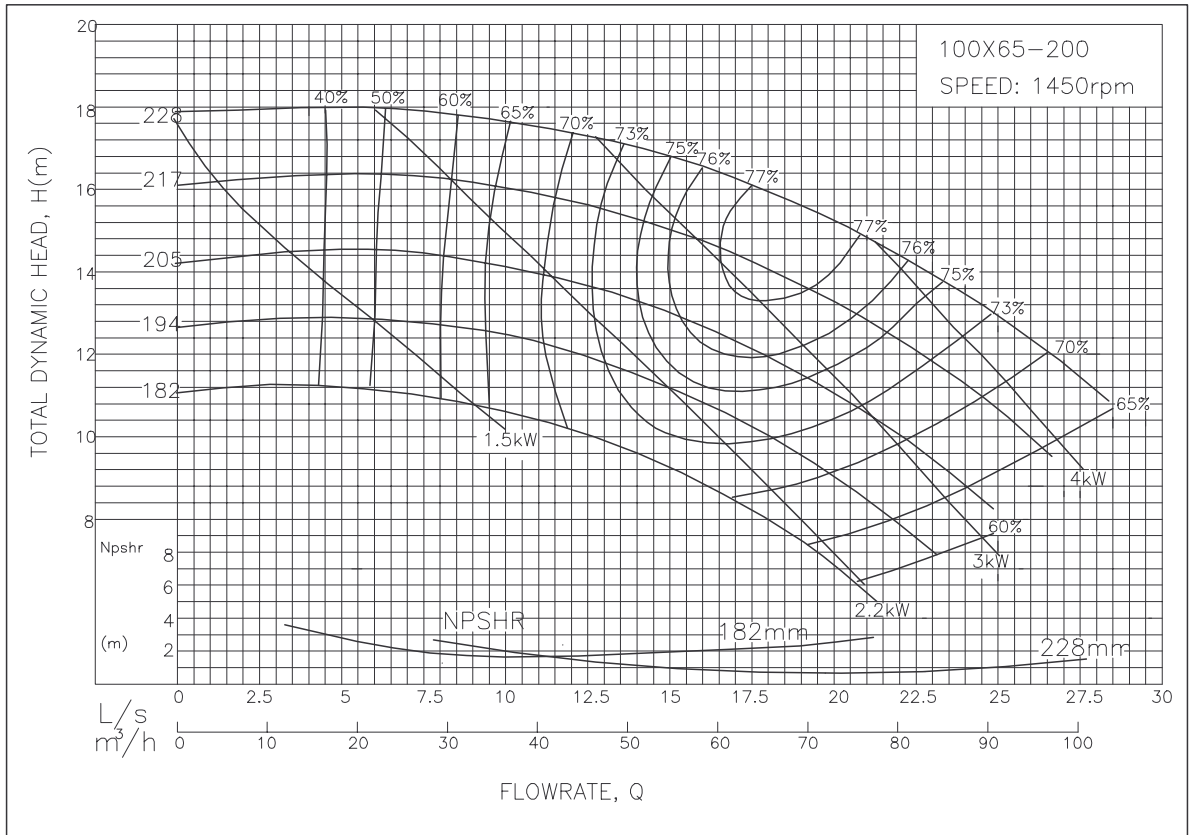

Performances for standard construction, clean cold water, efficiency correction for Stainless Steel construction 4%.

Goolds GIS Series

ISO End Suction Centrifugal Pump - 100x65-250 Performance Curve

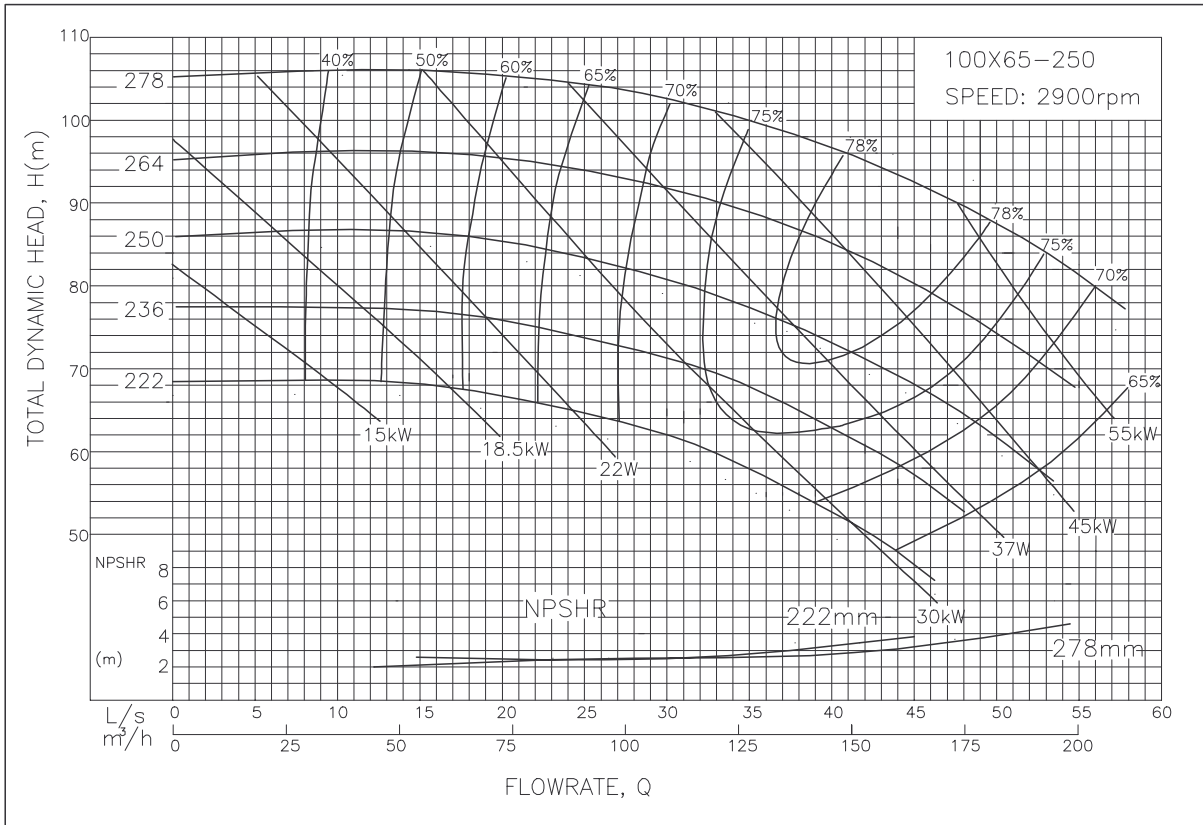
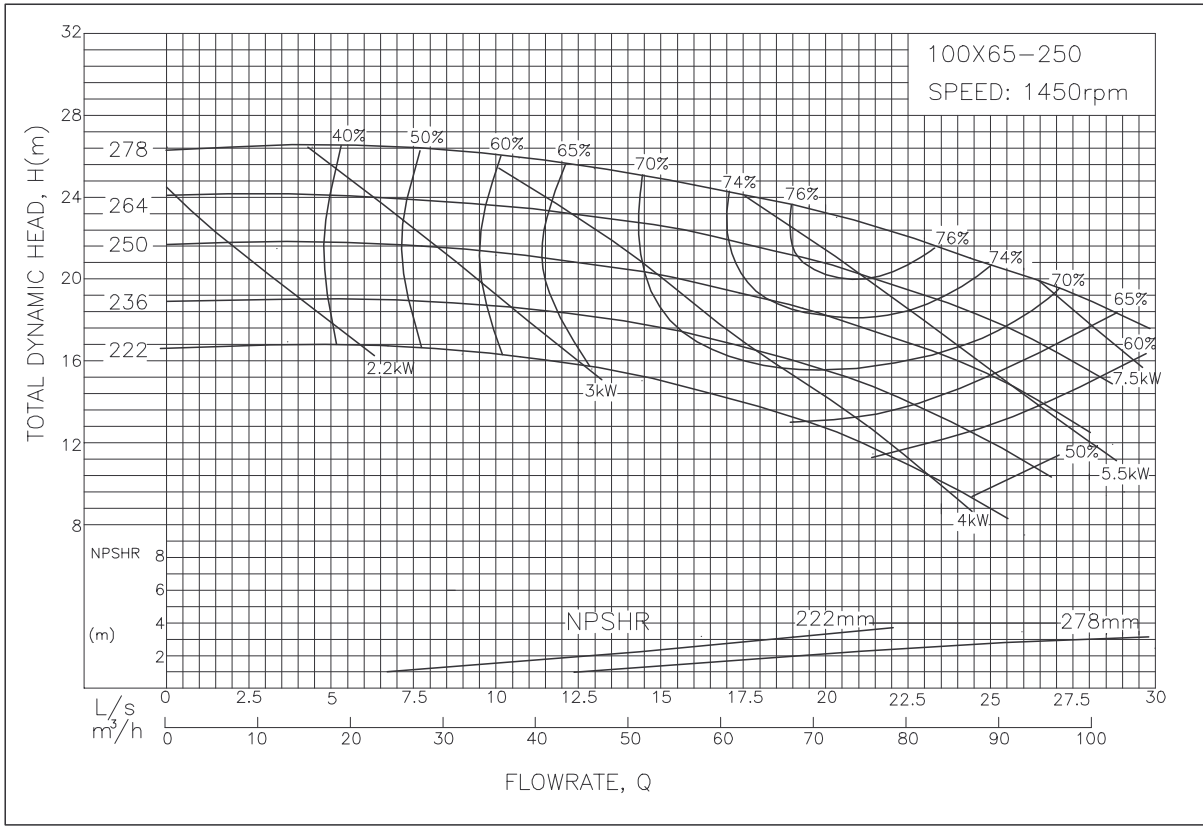

Performances for standard construction, clean cold water. Performance correction for Stainless Steel construction 4%.

Goolds GIS Series

ISO End Suction Centrifugal Pump - 100x65-315 Performance Curve

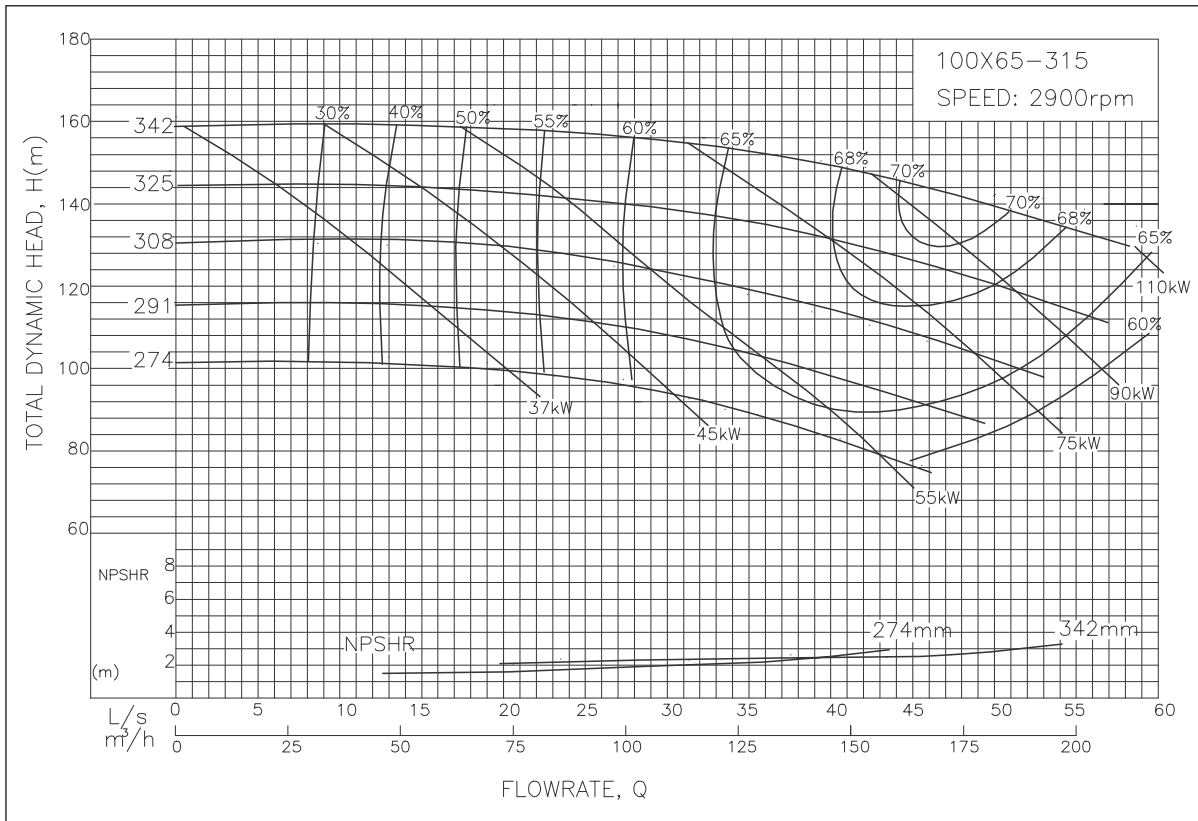
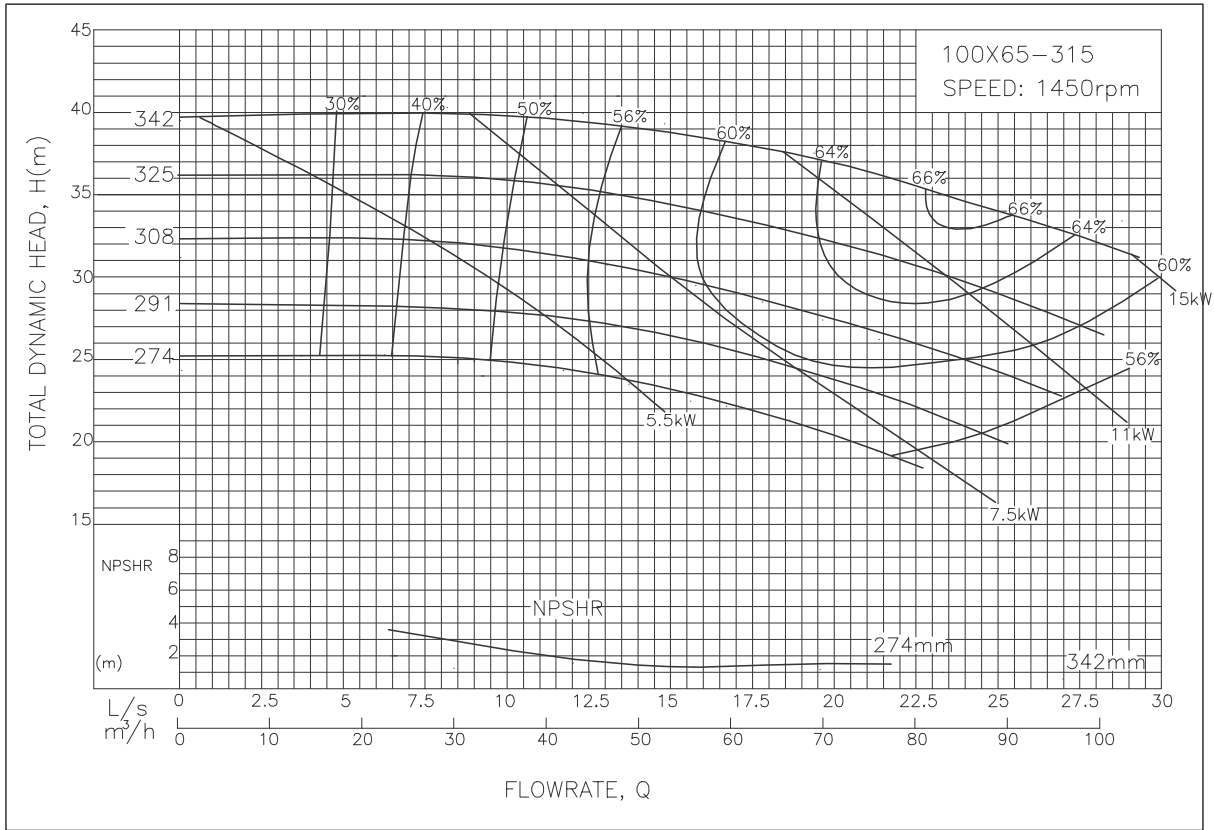

Performances for standard construction, clean cold water, efficiency correction for Stainless Steel construction 4%.

Goolds GIS Series

ISO End Suction Centrifugal Pump - 100x80-160 Performance Curve

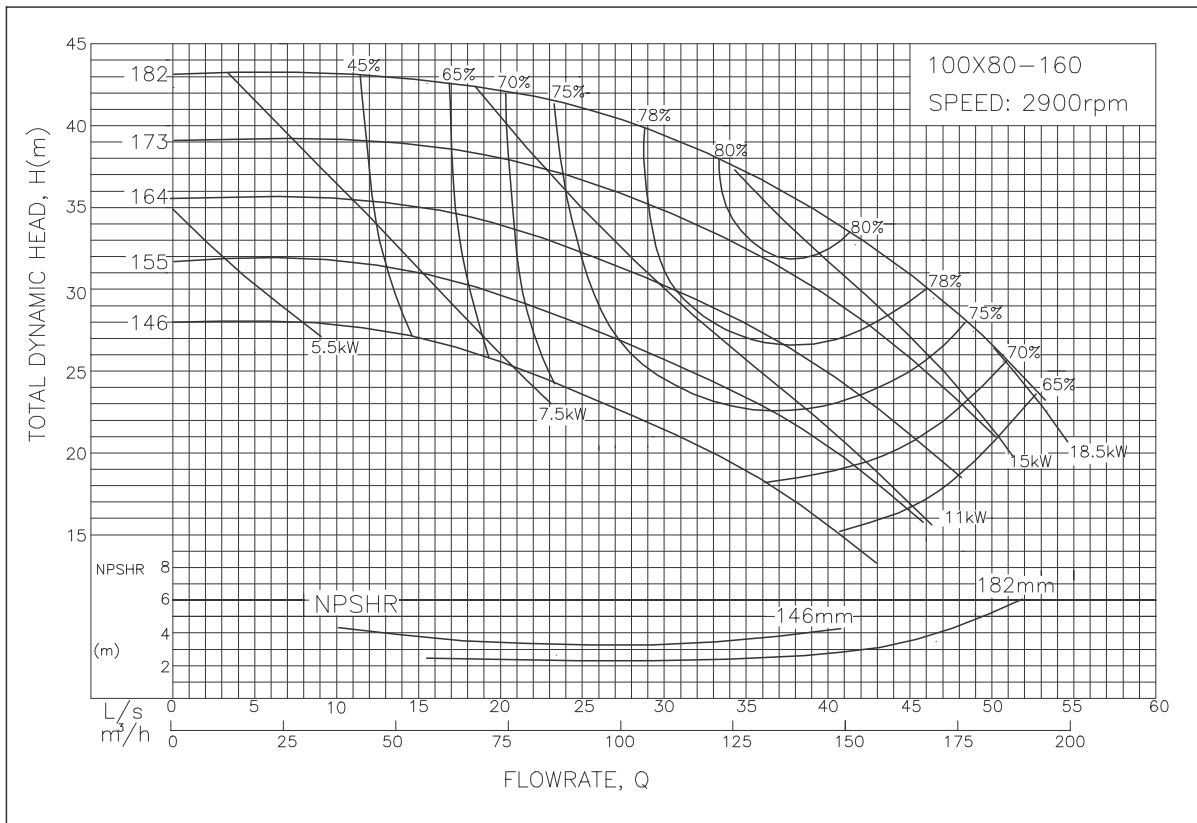
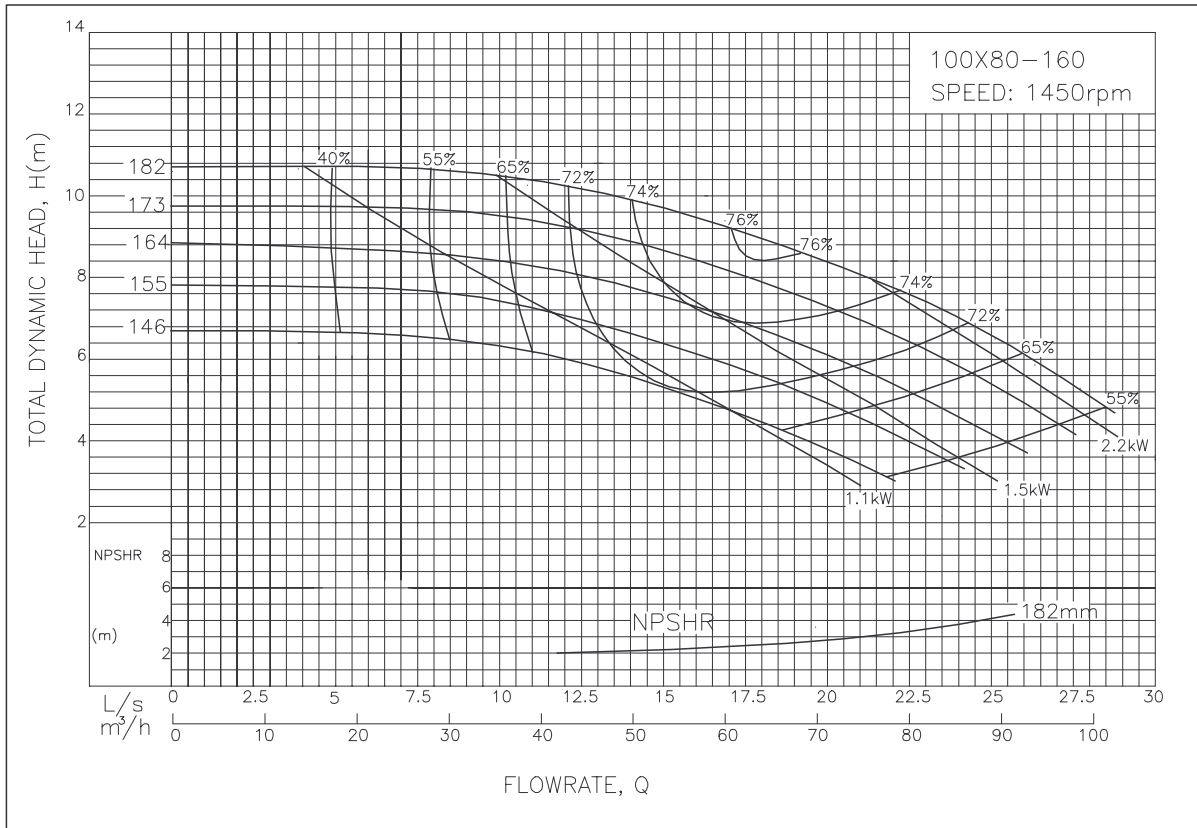

Performances for standard construction, clean cold water. Performance correction for Stainless Steel construction 4%.

Goolds GIS Series

ISO End Suction Centrifugal Pump - 125x80-400 Performance Curve

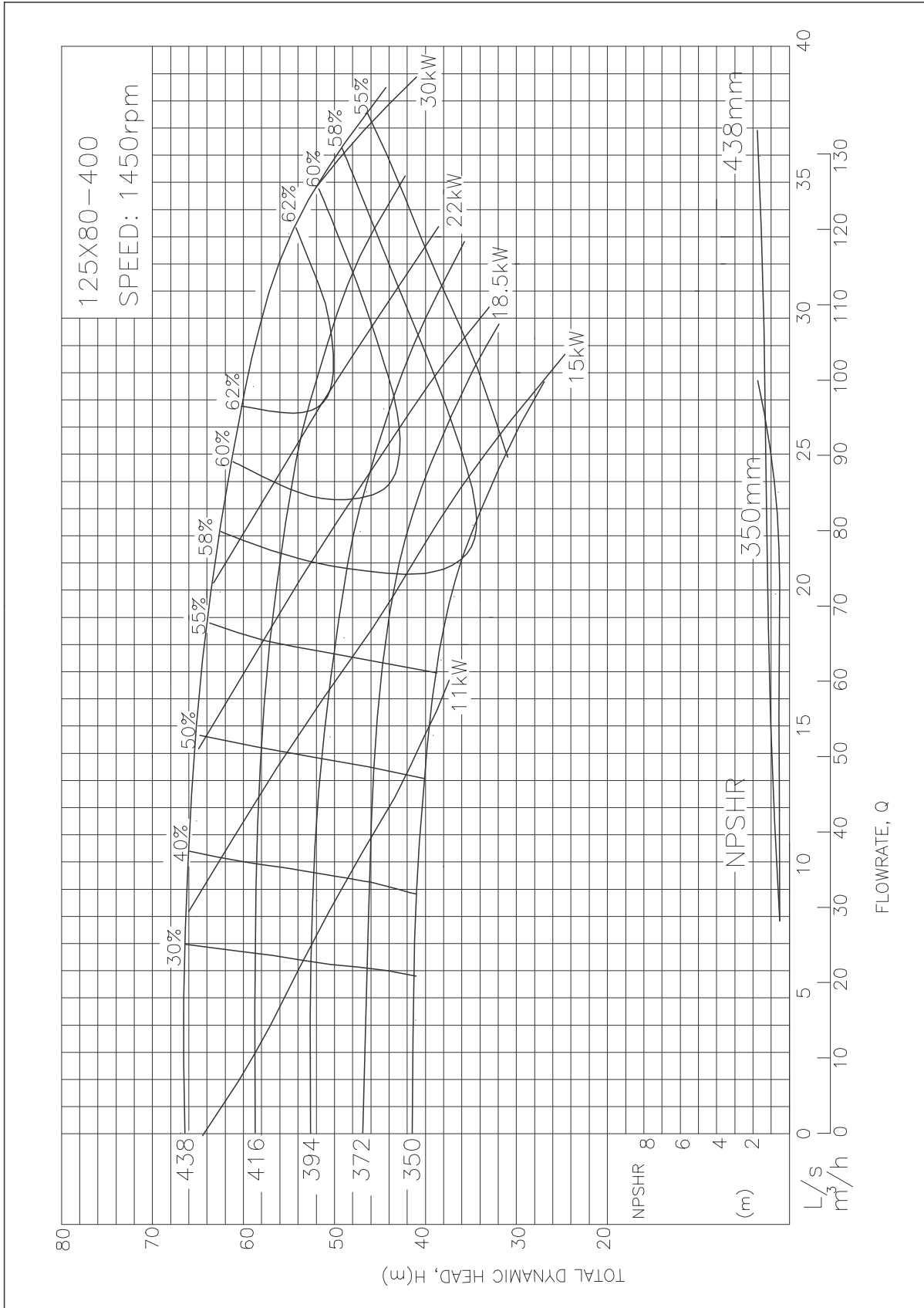

Performances for standard construction, clean cold water, efficiency correction for Stainless Steel construction 4%.

Goolds GIS Series

ISO End Suction Centrifugal Pump - 125x100-200 Performance Curve

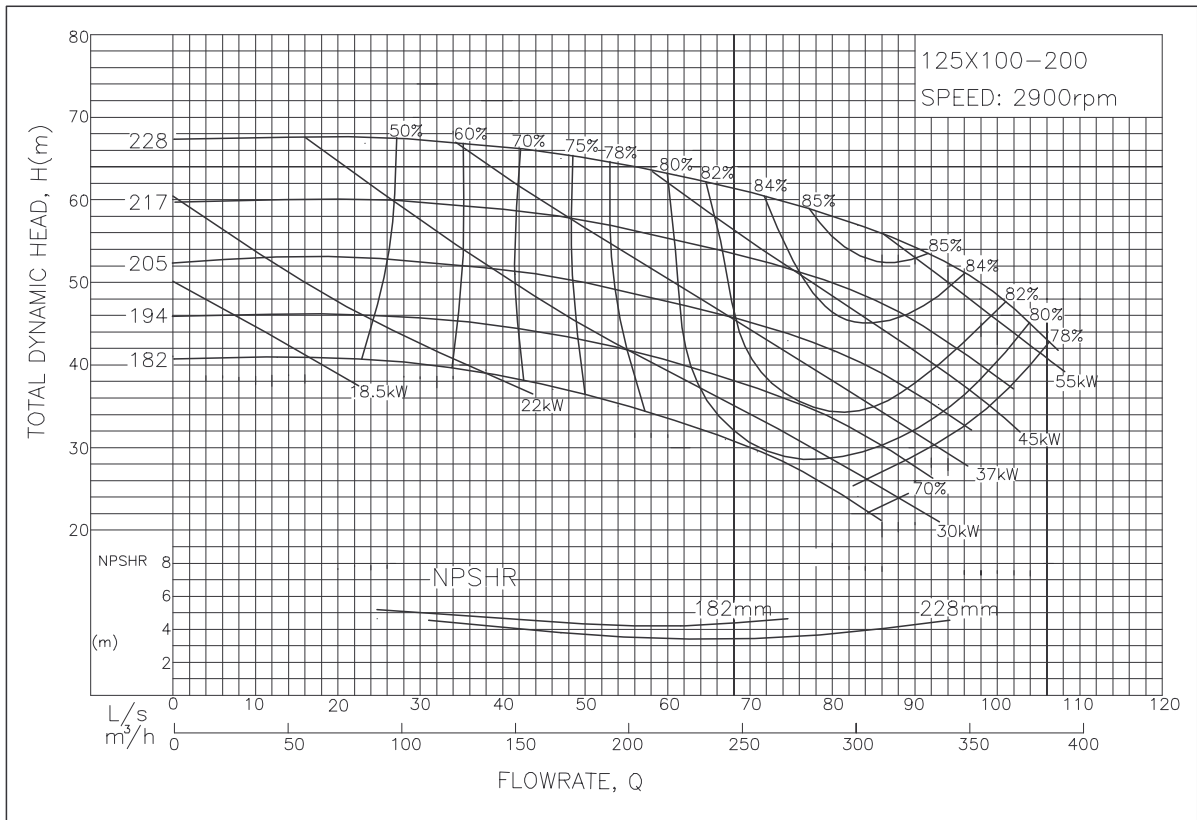
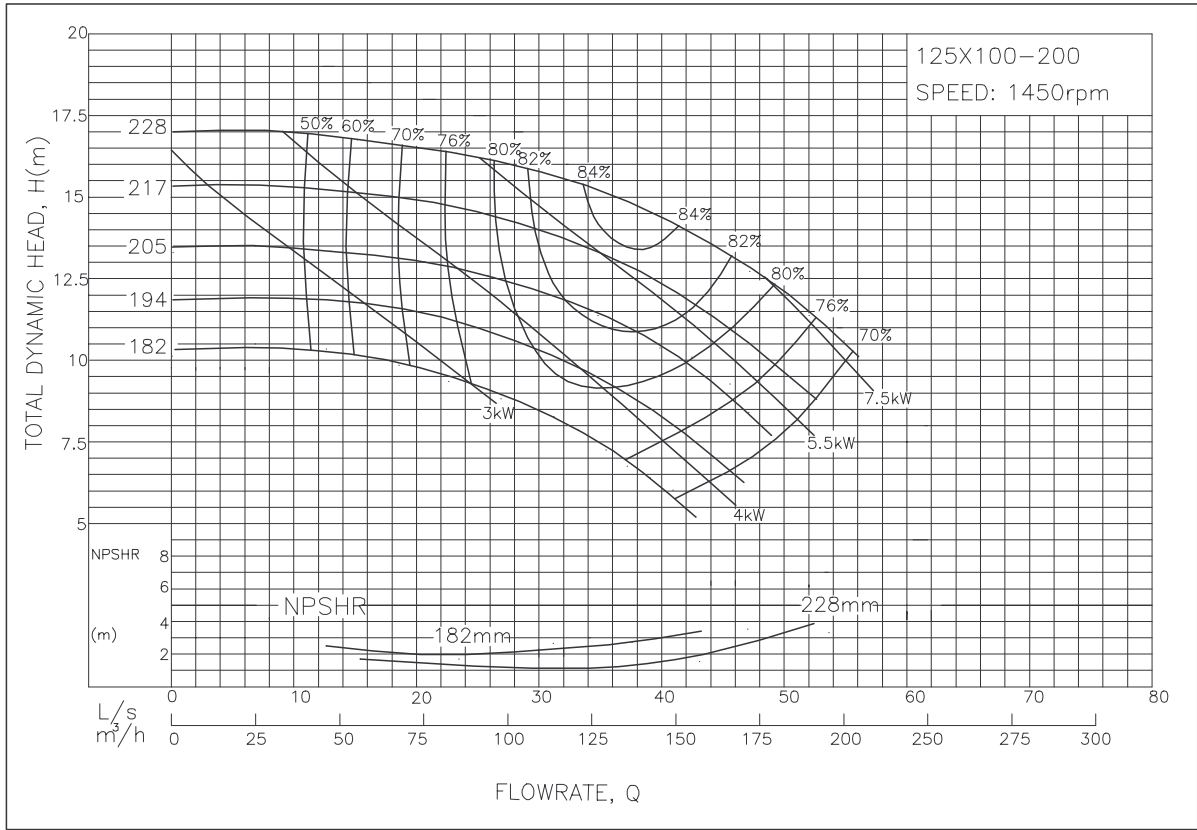

Performances for standard construction, clean cold water. Performance correction for Stainless Steel construction 4%.

Goolds GIS Series

ISO End Suction Centrifugal Pump - 125x100-250 Performance Curve

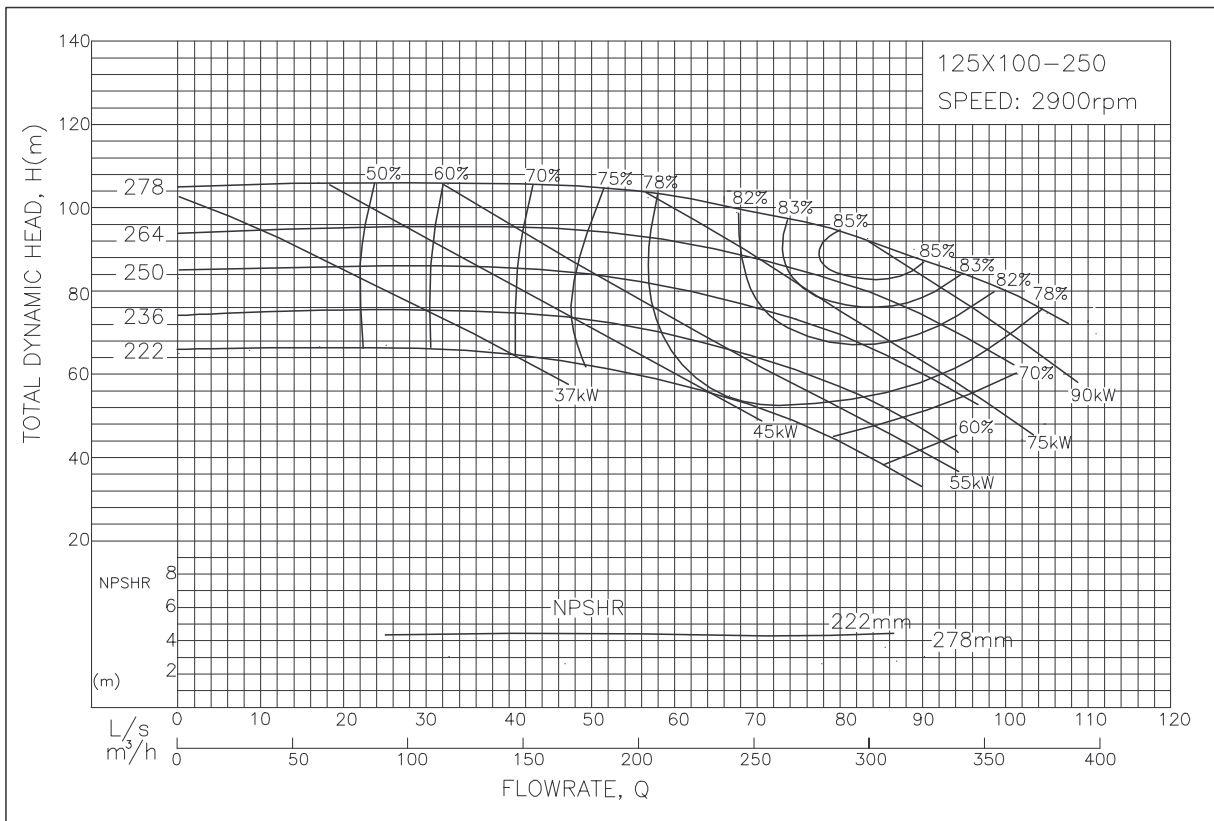
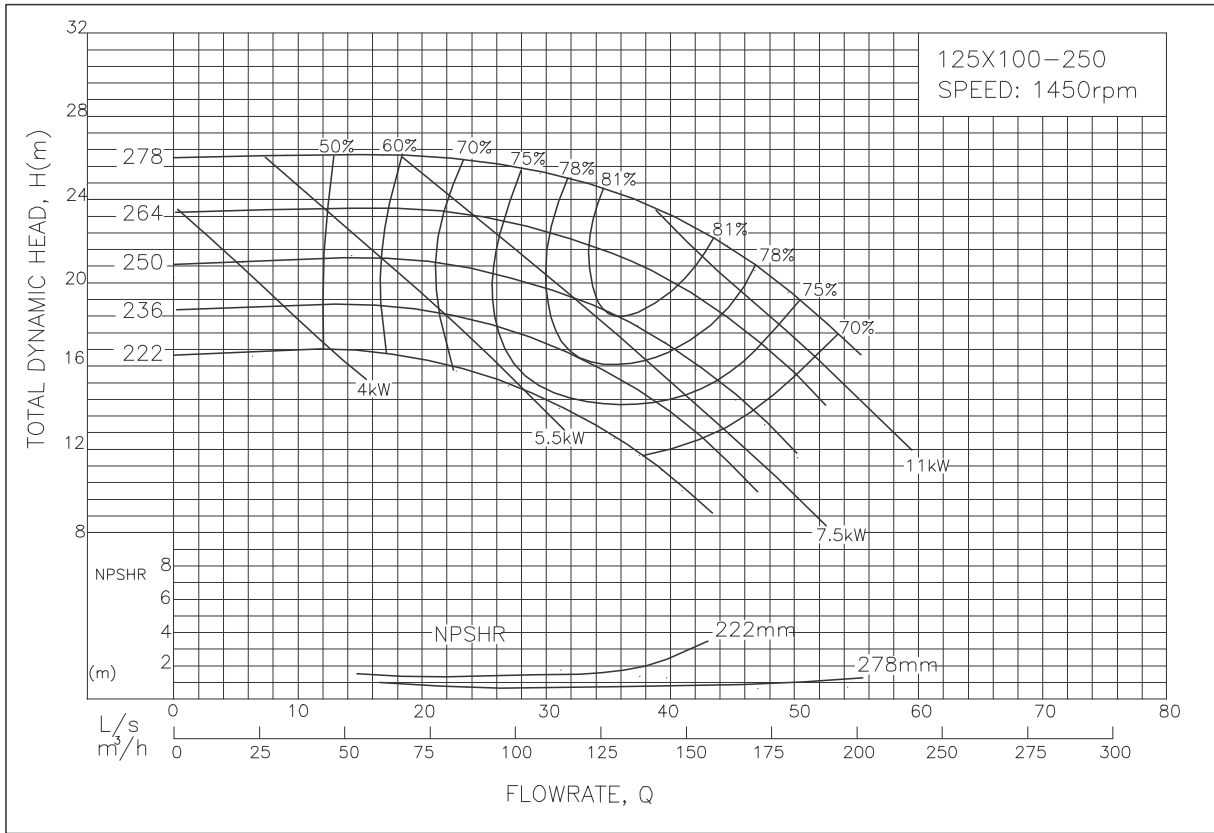

Performances for standard construction, clean cold water, efficiency correction for Stainless Steel construction 4%.

Goolds GIS Series

ISO End Suction Centrifugal Pump - 125x100-315 Performance Curve

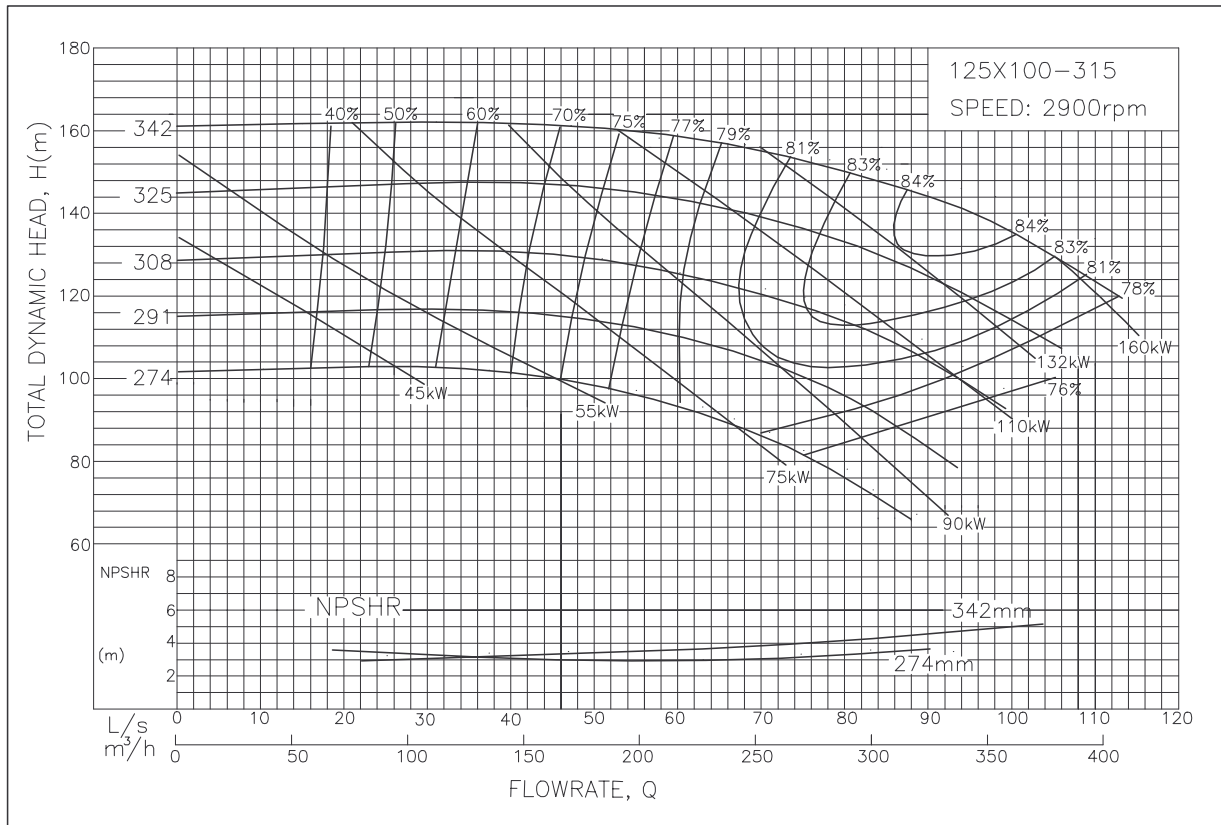
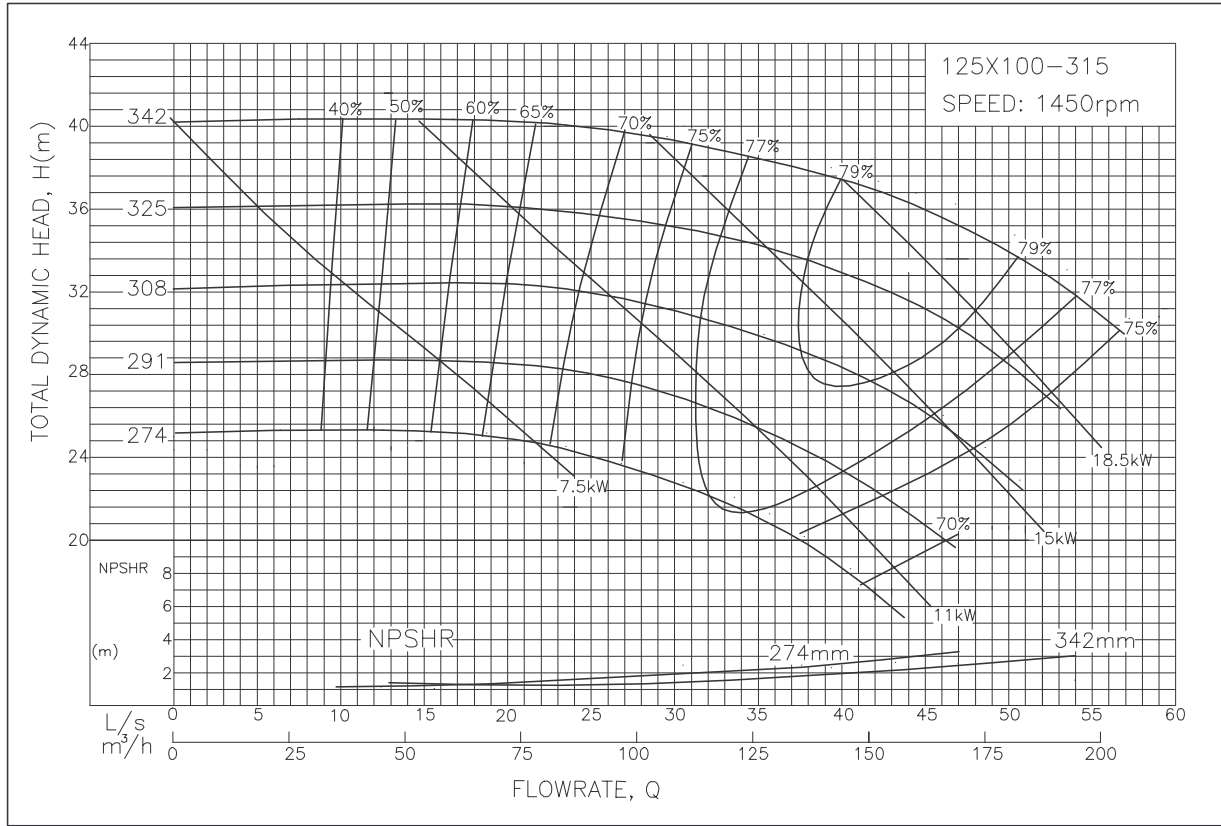

Performances for standard construction, clean cold water. Performance correction for Stainless Steel construction 4%.

Goolds GIS Series

ISO End Suction Centrifugal Pump - 125x100-400 Performance Curve

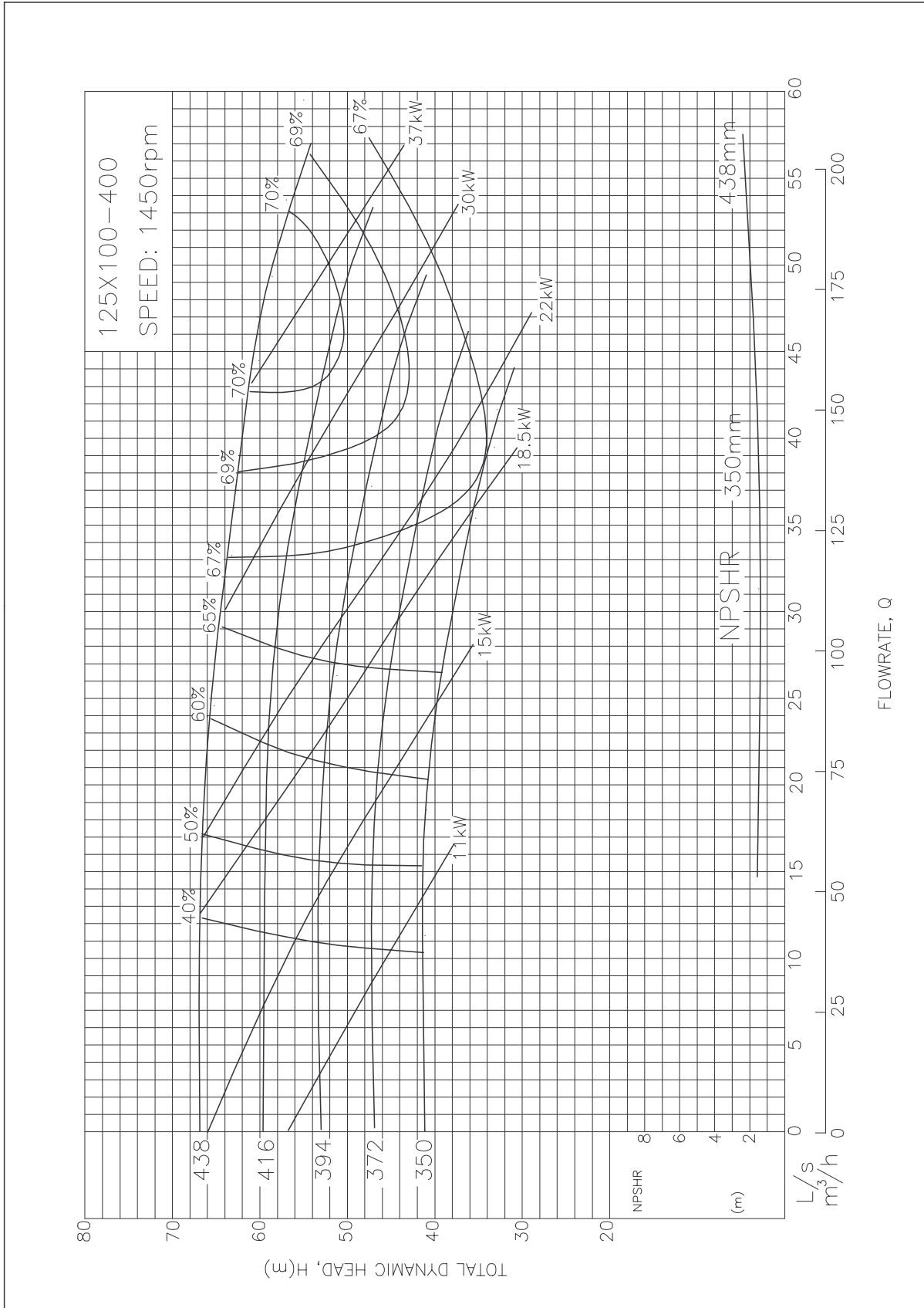

Performances for standard construction, clean cold water, efficiency correction for Stainless Steel construction 4%.

Goolds GIS Series

ISO End Suction Centrifugal Pump - 125x100-500 Performance Curve

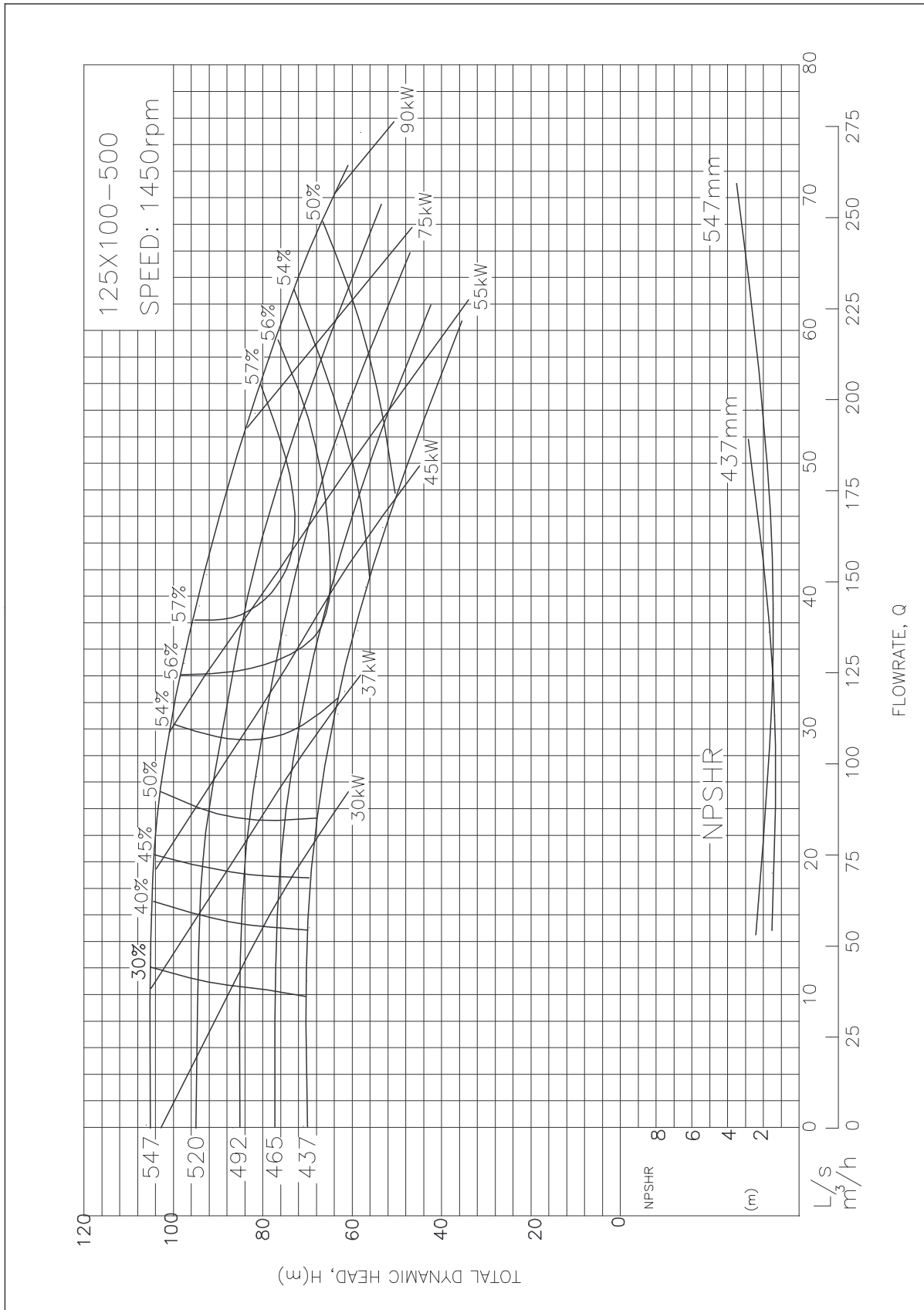

Performances for standard construction, clean cold water. Performance correction for Stainless Steel construction 4%.

Goolds GIS Series

ISO End Suction Centrifugal Pump - 150x125-250 Performance Curve

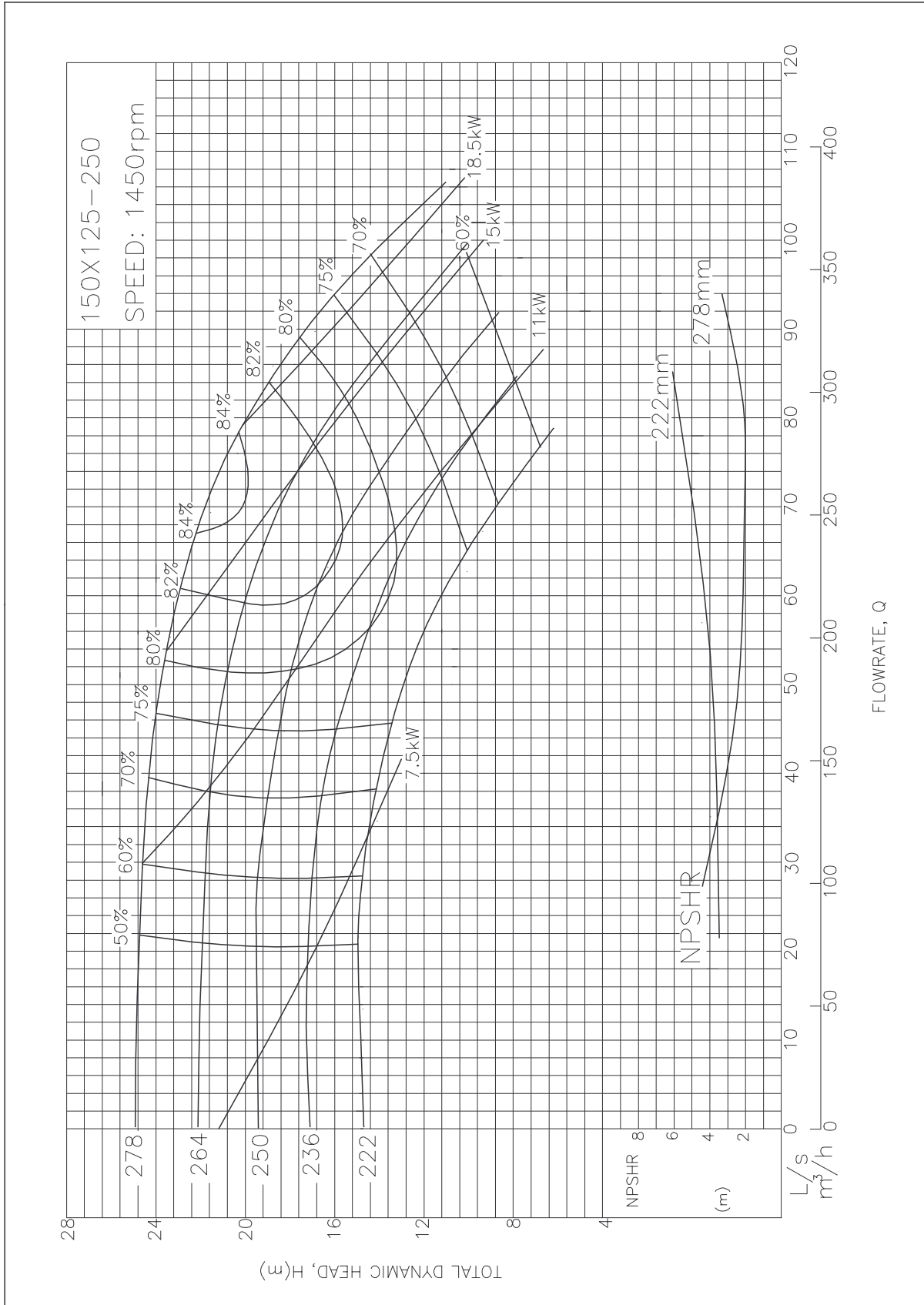

Performances for standard construction, clean cold water, efficiency correction for Stainless Steel construction 4%.

Goolds GIS Series

ISO End Suction Centrifugal Pump - 150x125-315 Performance Curve

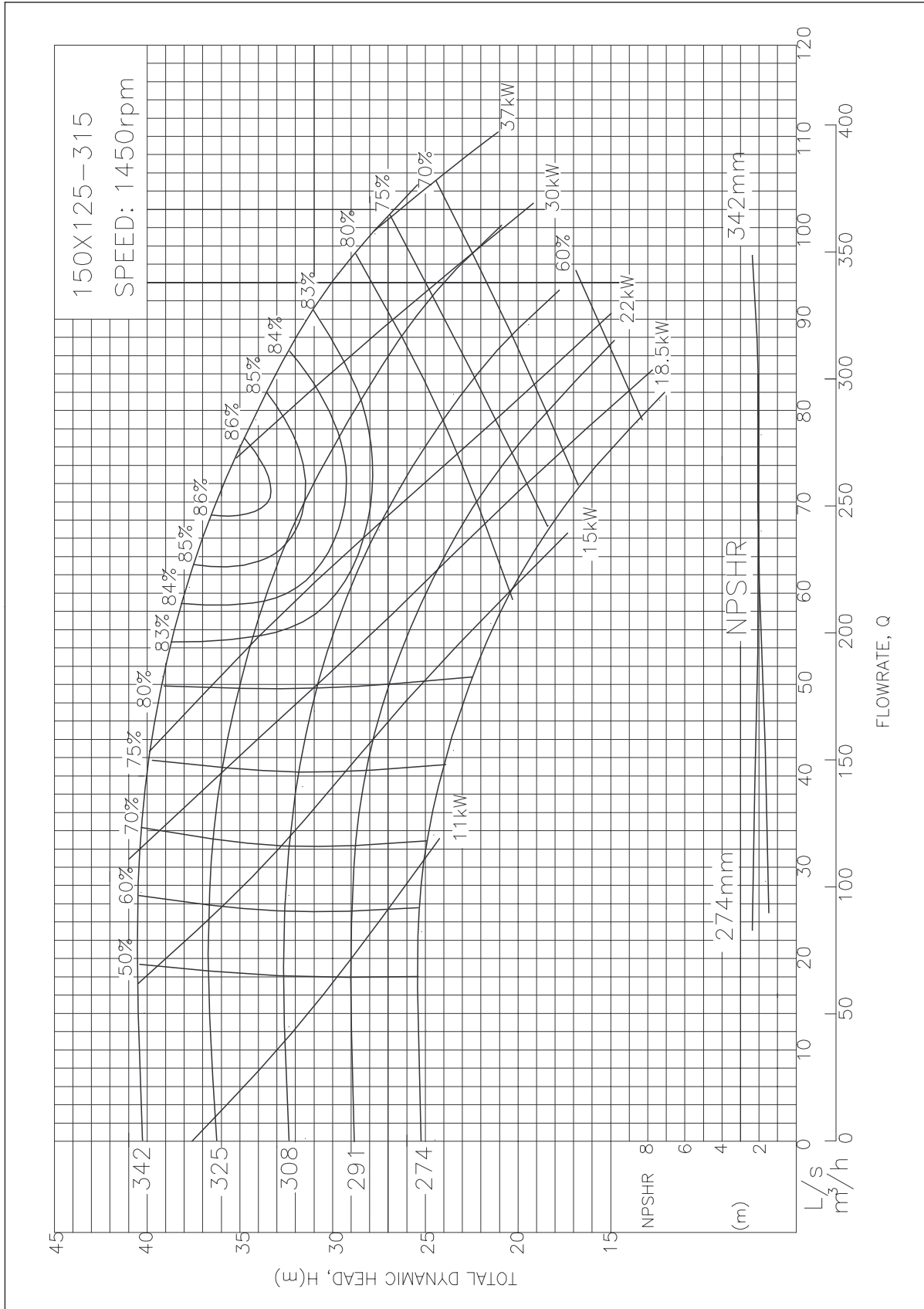

Performances for standard construction, clean cold water. Performance correction for Stainless Steel construction 4%.

Goolds GIS Series

ISO End Suction Centrifugal Pump - 150x125-400 Performance Curve

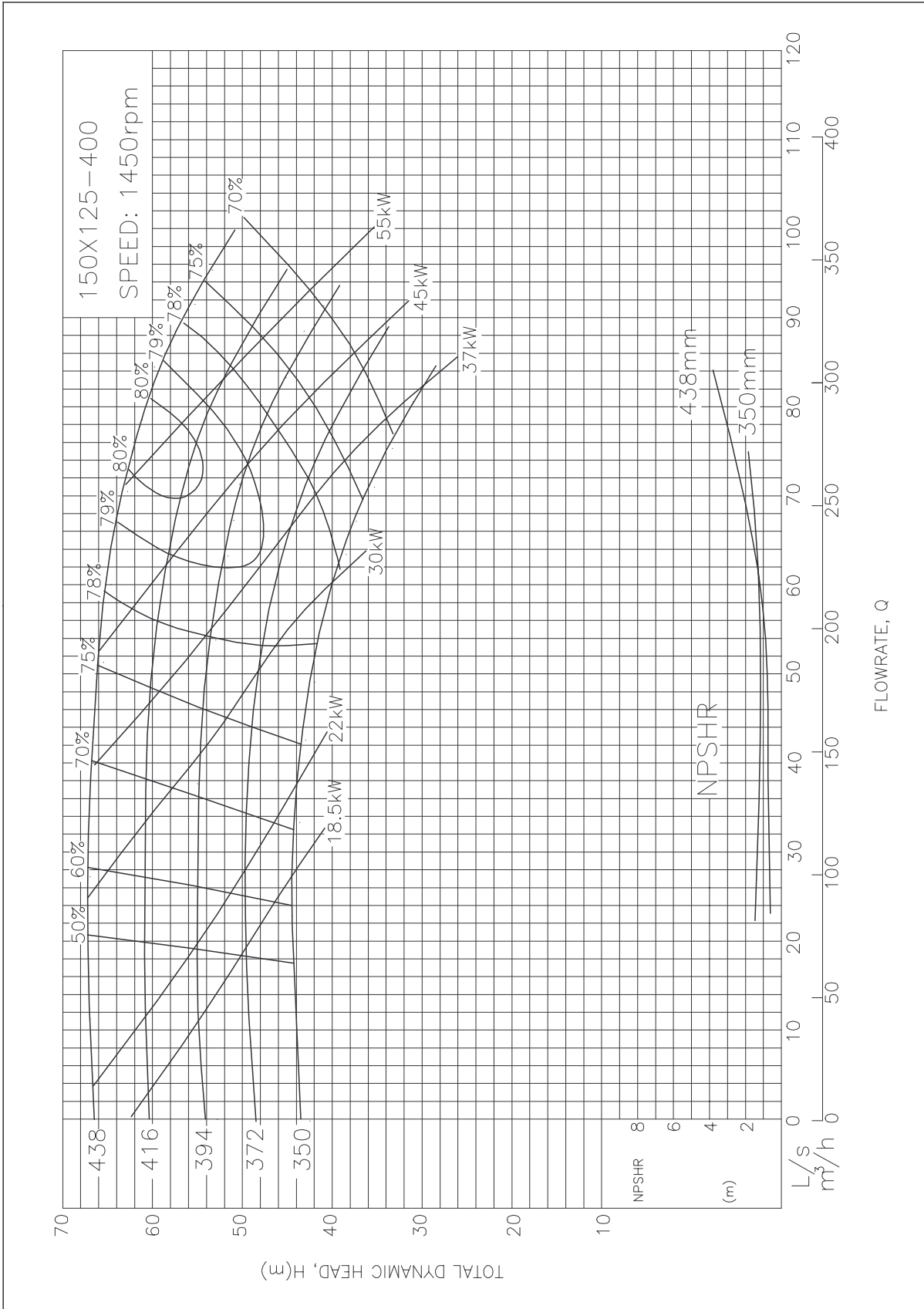

Performances for standard construction, clean cold water, efficiency correction for Stainless Steel construction 4%.

Goolds GIS Series

ISO End Suction Centrifugal Pump - 150x125-500 Performance Curve

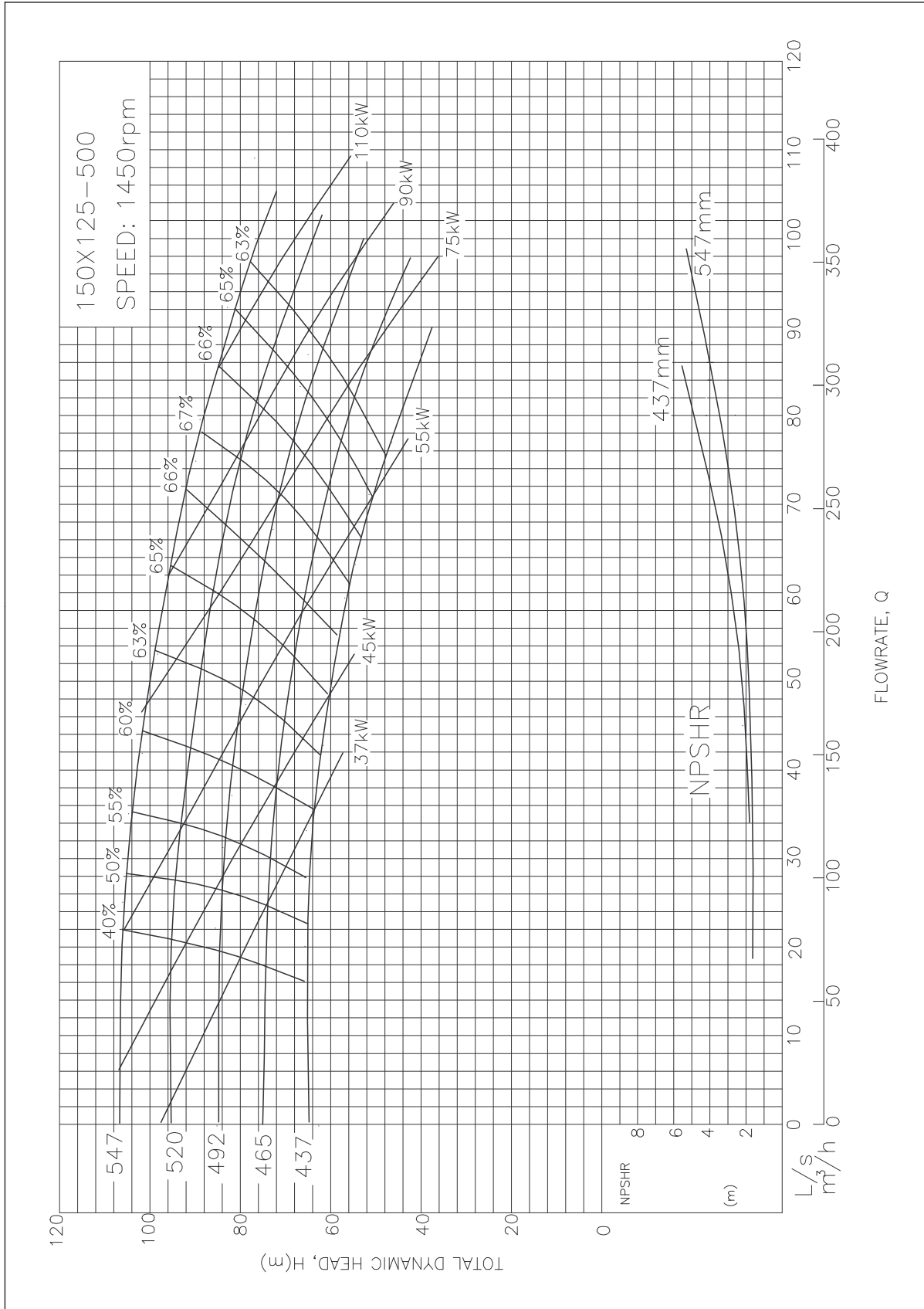

Performances for standard construction, clean cold water. Performance correction for Stainless Steel construction 4%.

Goolds GIS Series

ISO End Suction Centrifugal Pump - 200x150-315 Performance Curve

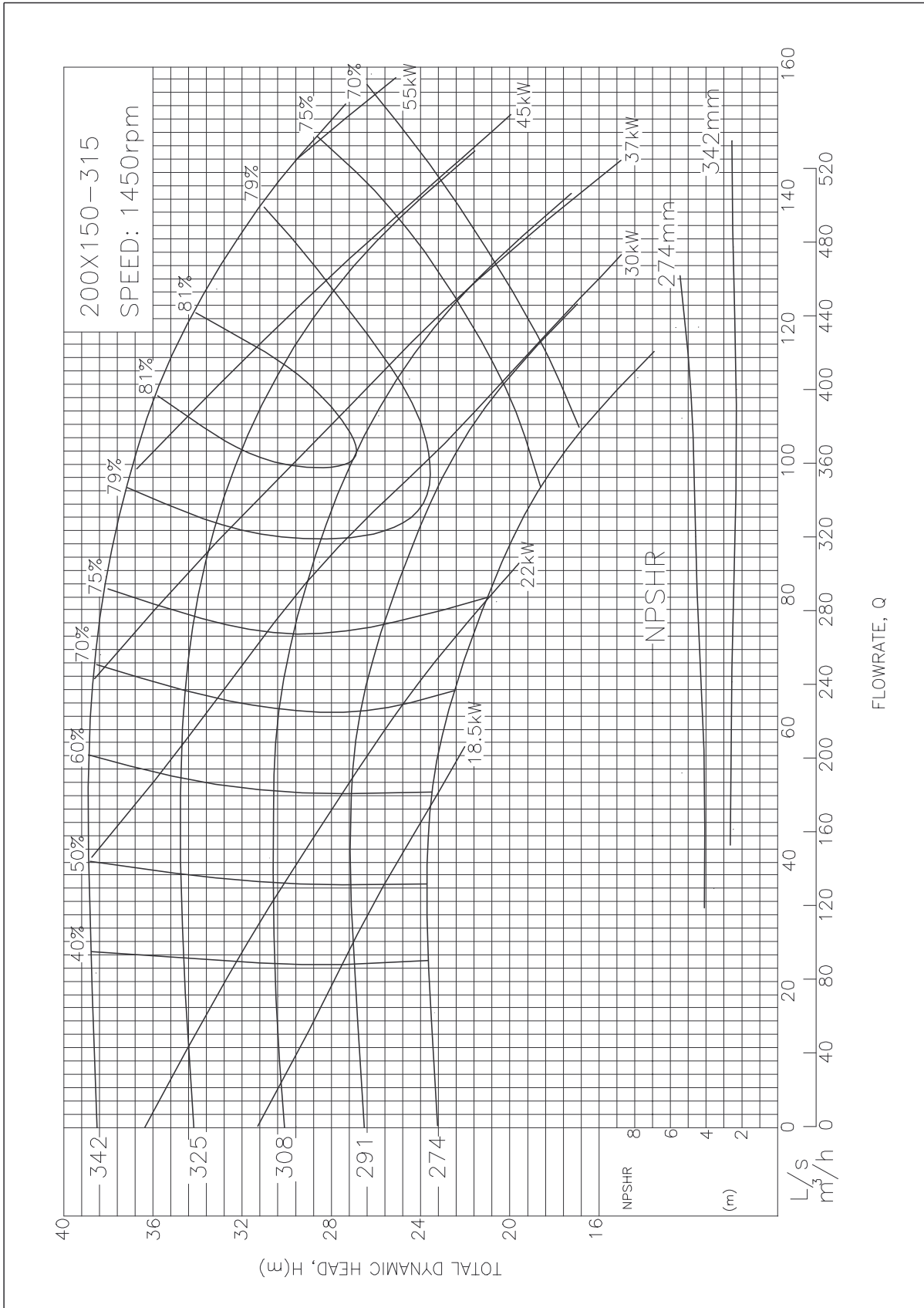

Performances for standard construction, clean cold water, efficiency correction for Stainless Steel construction 4%.

Goolds GIS Series

ISO End Suction Centrifugal Pump - 200x150-400 Performance Curve

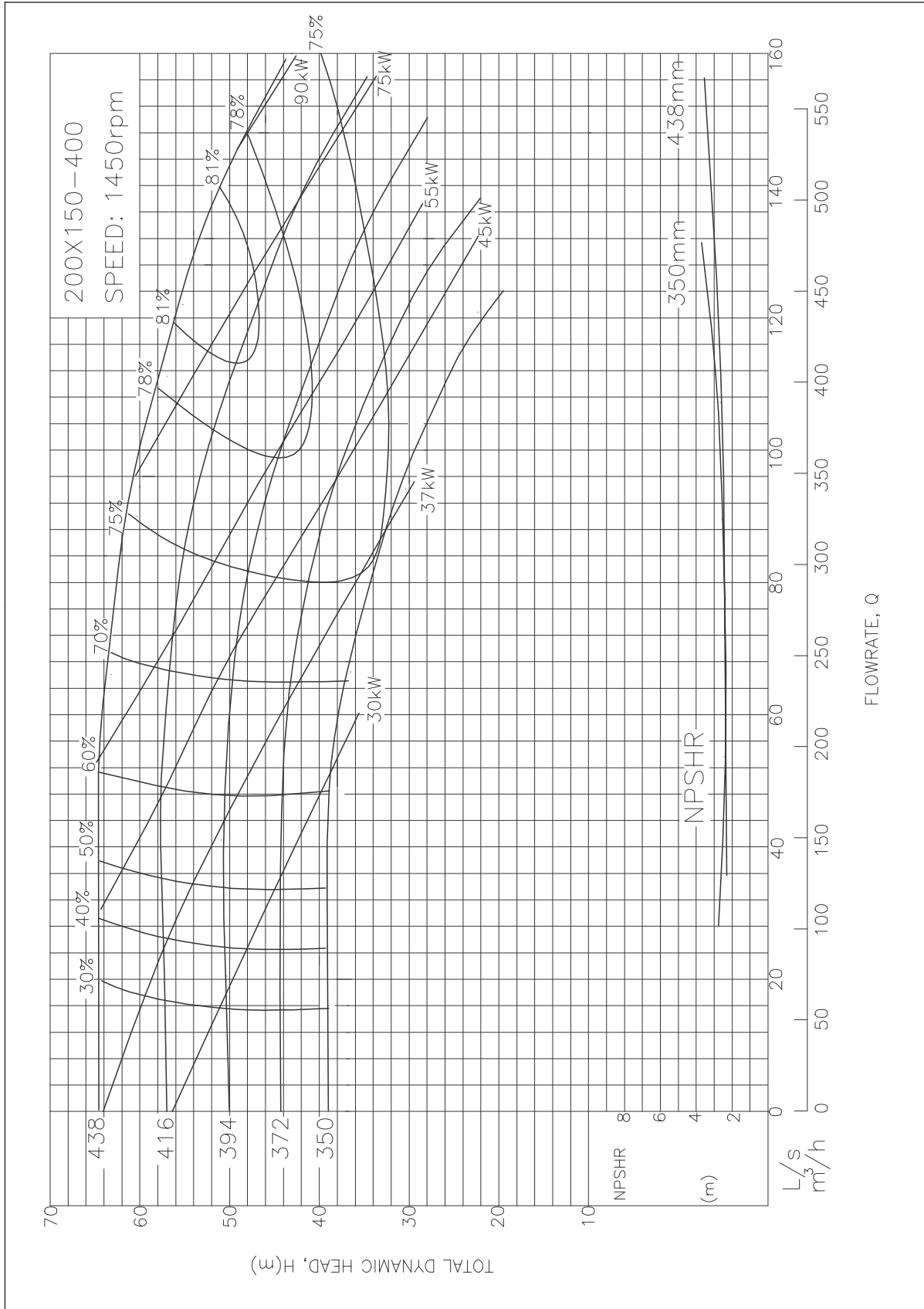

Performances for standard construction, clean cold water. Performance correction for Stainless Steel construction 4%.

Goolds GIS Series

ISO End Suction Centrifugal Pump - 200x150-500 Performance Curve

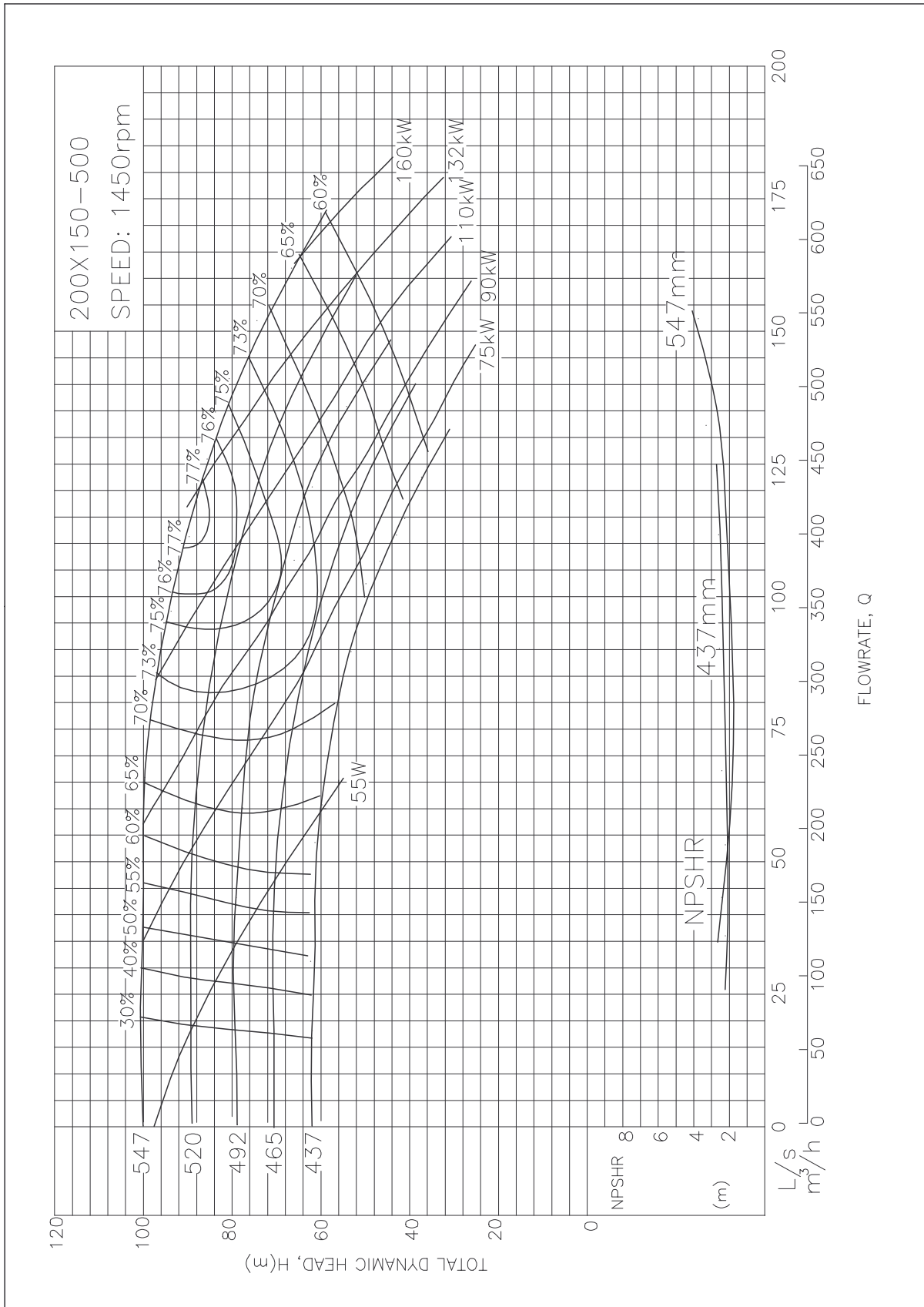

Performances for standard construction, clean cold water, efficiency correction for Stainless Steel construction 4%.

Goolds GIS Series

ISO End Suction Centrifugal Pump - 250x200-315 Performance Curve

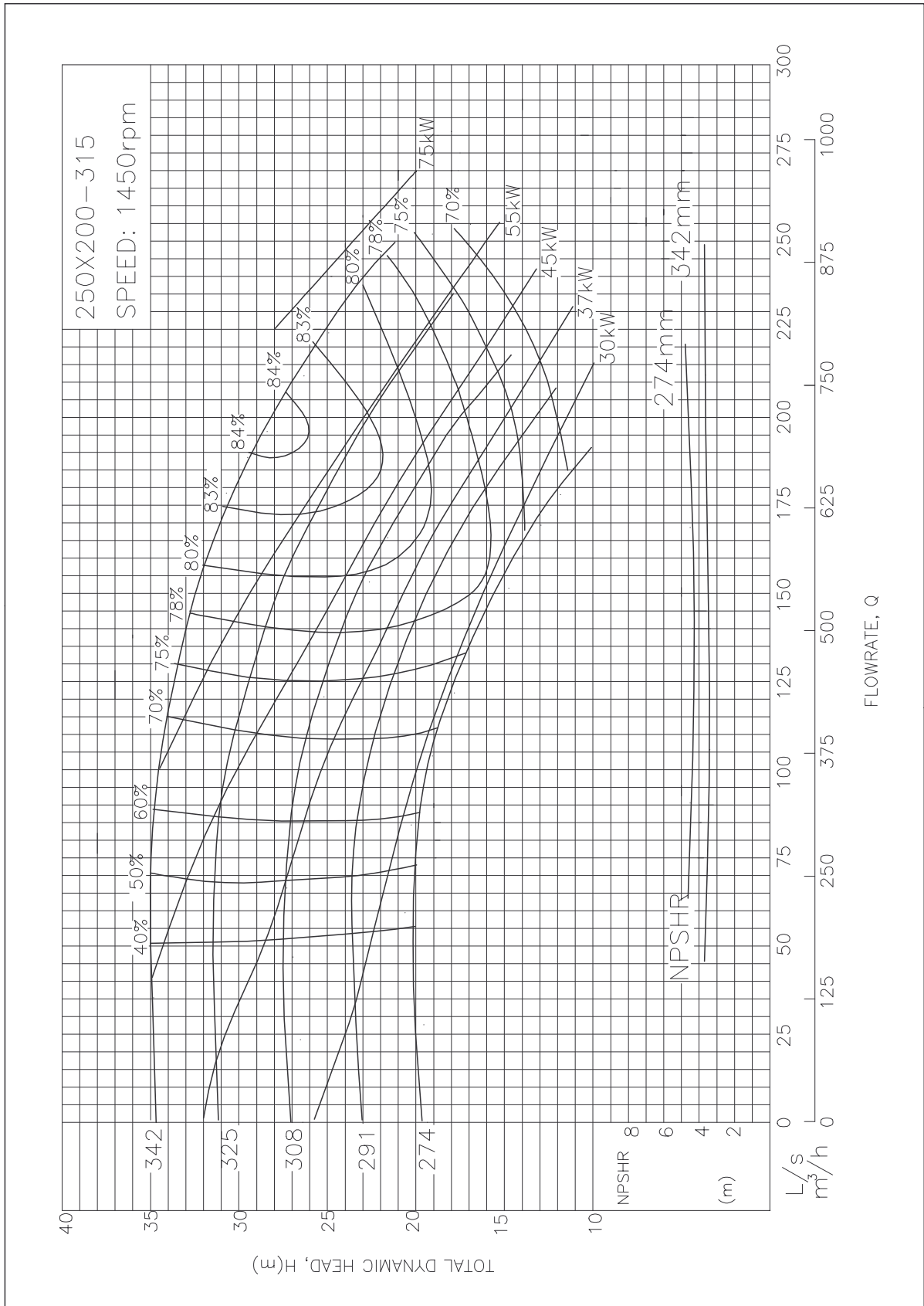

Performances for standard construction, clean cold water. Performance correction for Stainless Steel construction 4%.

Goolds GIS Series

ISO End Suction Centrifugal Pump - 250x200-400 Performance Curve

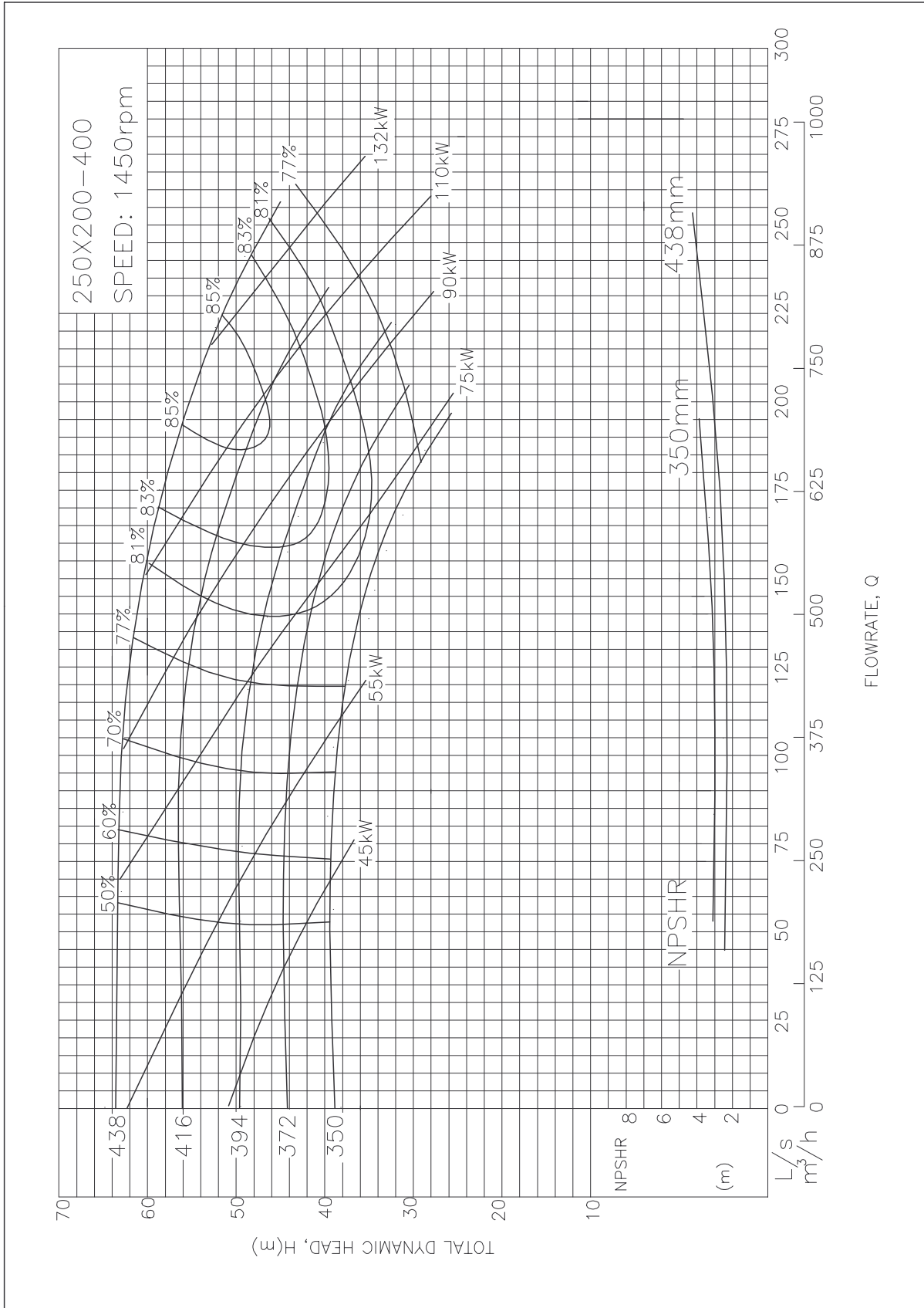

Performances for standard construction, clean cold water, efficiency correction for Stainless Steel construction 4%.

Goolds GIS Series

ISO End Suction Centrifugal Pump - Frame Mount Pump Dimensions

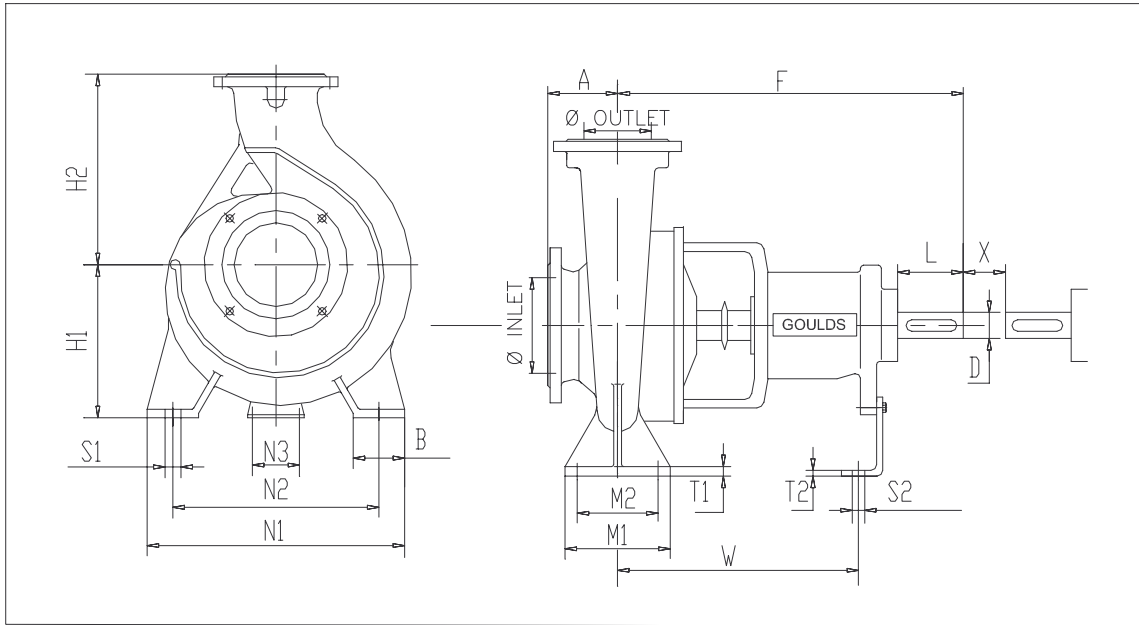

PUMP			Shaft No.	Pump dimensions				Mounting Dimensions									Bolt Holes		Shaft End		Gap	Weight kg
IN	OUT	IMP		A	F	H1	H2	B	M1	M2	N1	N2	N3	T1	T2	W	S1	S2	D	L		
50	32	160	1	80	385	132	160	50	100	70	240	190	110	12	6	285	M12	M12	24	50	100	38
50	32	200	1	80	385	160	180	50	100	70	240	190	110	12	6	285	M12	M12	24	50	100	46
65	50	160	1	80	385	132	160	50	100	70	240	190	110	12	6	285	M12	M12	24	50	100	40
65	40	200	1	100	385	160	180	50	100	70	265	212	110	13	6	285	M12	M12	24	50	100	48
65	40	250	2	100	500	180	225	65	125	95	320	250	110	14	6	370	M12	M12	32	80	100	70
65	40	315	2	125	500	200	250	65	125	95	345	280	110	16	6	370	M12	M12	32	80	100	80
80	65	160	1	100	385	160	180	50	100	70	265	212	110	13	6	285	M12	M12	24	50	100	46
80	50	200	1	100	385	160	200	50	100	70	265	212	110	13	6	285	M12	M12	24	50	100	52
80	50	250	2	125	500	180	225	65	125	95	320	250	110	15	6	370	M12	M12	32	80	100	72
80	50	315	2	125	500	225	280	65	125	95	345	280	110	18	6	370	M12	M12	32	80	100	87
100	80	160	2	100	500	160	200	65	125	95	280	212	110	14	6	370	M12	M12	32	80	100	68
100	65	200	2	100	500	180	225	65	125	95	320	250	110	14	6	370	M12	M12	32	80	140	70
100	65	250	2	125	500	200	250	80	160	120	360	280	110	16	6	370	M16	M12	32	80	140	80
100	65	315	3	125	530	225	280	80	160	120	400	315	110	18	6	370	M16	M12	42	110	140	118
125	80	400	3	125	530	280	355	80	160	120	435	355	110	20	6	370	M16	M12	42	110	140	165
125	100	200	2	125	500	200	280	80	160	120	360	280	110	17	6	370	M16	M12	32	80	140	85
125	100	250	3	140	530	225	280	80	160	120	400	315	110	18	6	370	M16	M12	42	110	140	126
125	100	315	3	140	530	250	315	80	160	120	400	315	110	19	6	370	M16	M12	42	110	140	135
125	100	400	3	140	530	280	355	100	200	150	500	400	110	20	6	370	M20	M12	42	110	140	175
125	100	500	4	160	670	355	450	100	200	150	550	450	110	25	10	500	M20	M16	48	110	180	313
150	125	250	3	140	530	250	355	80	160	120	400	315	110	19	6	370	M16	M12	42	110	140	140
150	125	315	3	140	530	280	355	100	200	150	500	400	110	20	6	370	M20	M12	42	110	140	150
150	125	400	3	140	530	315	400	100	200	150	500	400	110	21	6	370	M20	M12	42	110	140	186
150	125	500	4	160	670	355	450	100	200	150	550	450	140	25	10	500	M20	M16	48	110	180	336
200	150	315	4	160	670	315	400	100	200	150	550	450	140	25	10	500	M20	M16	48	110	180	222
200	150	400	4	160	670	315	450	100	200	150	550	450	140	25	10	500	M20	M16	48	110	180	300
200	150	500	4	160	670	400	500	100	200	150	550	450	140	25	10	500	M20	M16	48	110	180	382
250	200	315	4	180	670	315	450	100	200	150	550	450	140	25	10	500	M20	M16	48	110	180	277
250	200	400	4	180	670	355	500	100	200	150	550	450	140	25	10	500	M20	M16	48	110	180	340

- Remarks**
1. Standard flange drilling to AS 2129-1982 Table "E"
 2. Other drilling options available on request
 3. Dimensions in mm
 4. Gap 'x' is the minimum necessary for the withdrawal of bearing housing, back cover and impeller assembly towards drive end

Goulds GIS Series

ISO End Suction Centrifugal Pump - Frame Mount Shaft Dimensions

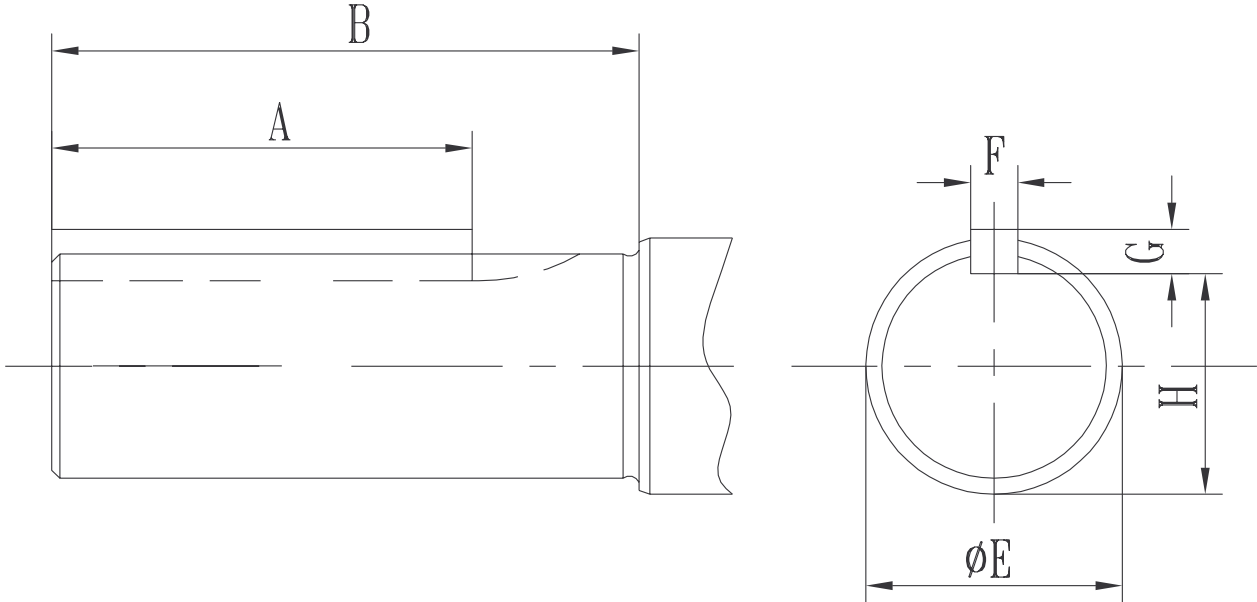

Shaft Module	Dimension 'E'		Key Width 'F'	Key Height 'G'	Key Way 'H'		Key Length 'A'	Shaft Extension 'B'
	Diameter	Tolerance			Dimension	Tolerance		
1	24	+0.015	8	7	20	0	32	50
		+0.002				-0.2		
2	32	+0.018	10	8	27	0	50	80
		+0.002				-0.2		
3	42	+0.018	12	8	37	0	80	110
		+0.002				-0.2		
4	48	+0.018	14	9	42.5	0	80	110
		+0.002				-0.2		

Dimensions in mm

Goulds GIS Series

ISO End Suction Centrifugal Pump - Frame Mount Grease-Lubricated Sectional Drawing

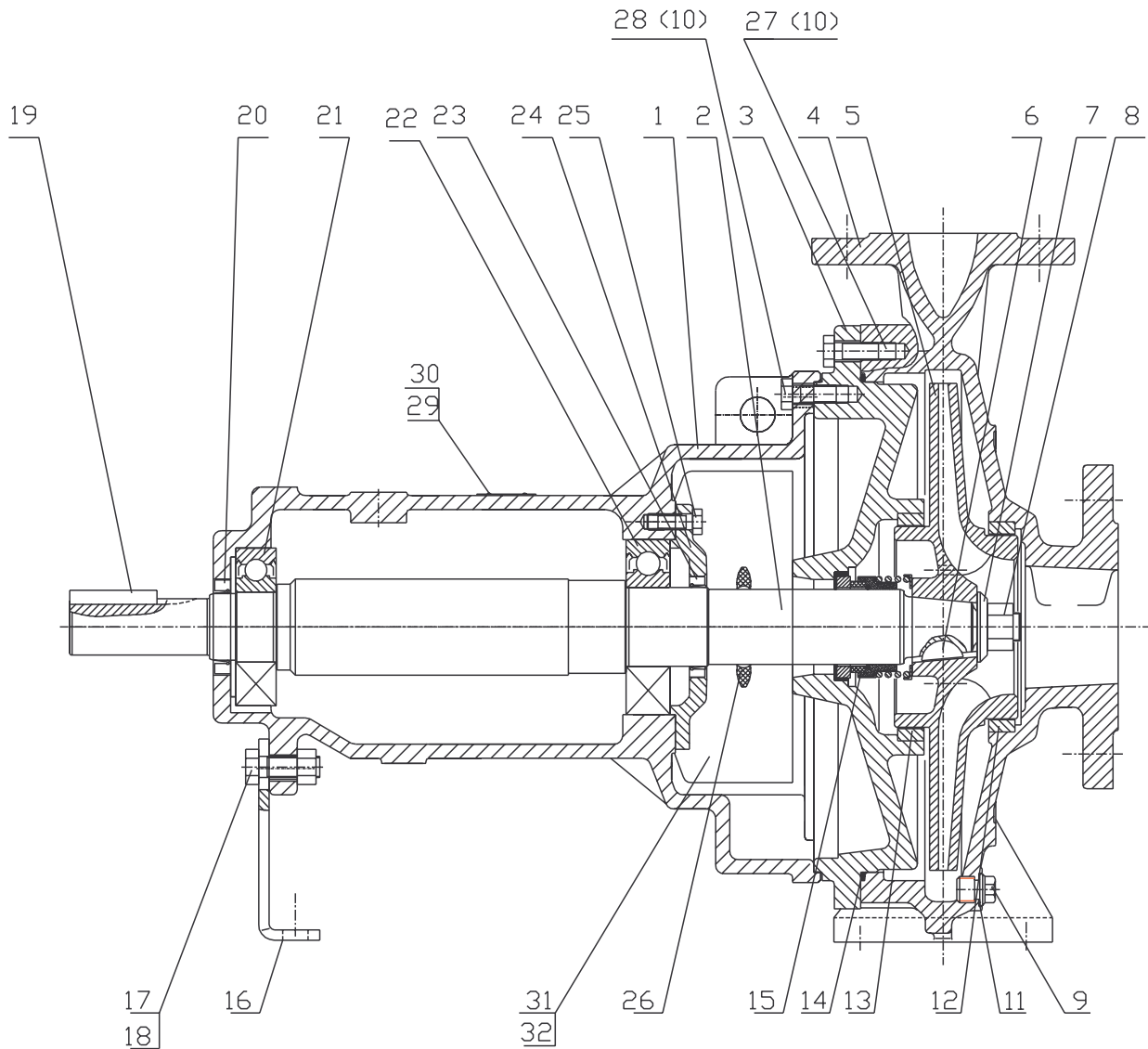

Item No.	Description	Item No.	Description	Item No.	Description
1	Bearing Housing	2	Shaft	3	Backplate
4	Pump Casing	5	Impeller	6	Impeller Key
7	Impeller Washer	8	Impeller Nut	9	Drain Plug
10	BRG Housing to Casing Bolt	11	Pug Gasket	12	Front Wear Ring
13	Rear Wear Ring	14	Casing O-ring	15	Mechanical Seal
16	Support Foot	17	Support Foot to BRG HSG Bolt	18	Support Foot to BRG HSG Nut
19	Coupling Key	20	Dust Seal - Drive end	21	Bearing - Drive end
22	Bearing - Impeller end	23	Dust Seal - Impeller end	24	Bearing Cover
25	BRG Cover to BRG HSG Bolt	26	Slinger	27	Backplate to Casing Bolt
28	BRG HSG to Backplate Bolt	29	Rivet	30	Nameplate
31	BRG HSG Safeguard	32	Safeguard to BRG HSG Screw		

Goolds GIS Series

ISO End Suction Centrifugal Pump - Frame Mount Shaft Module #1

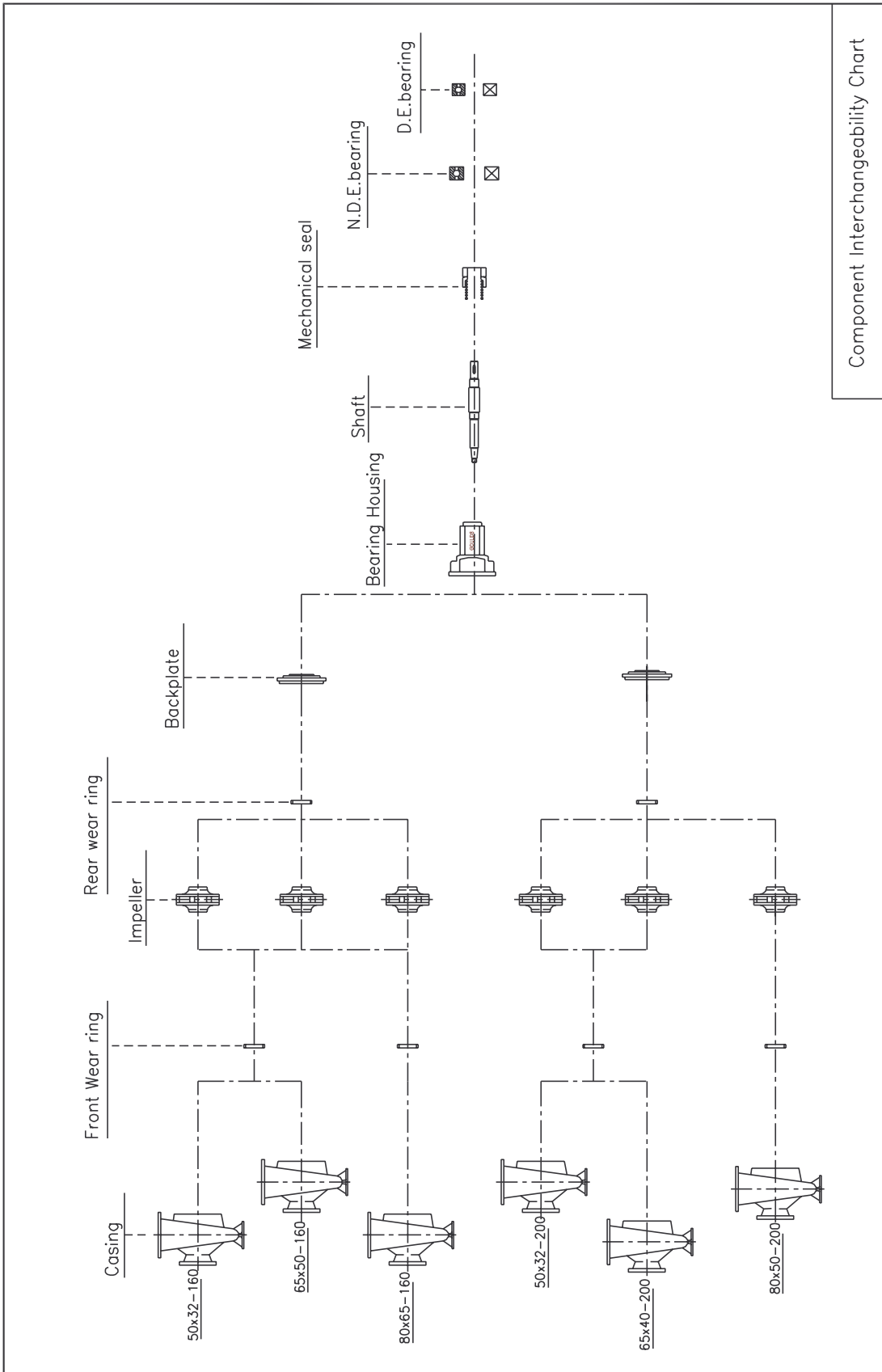

Goolds GIS Series

ISO End Suction Centrifugal Pump - Frame Mount Shaft Module #2

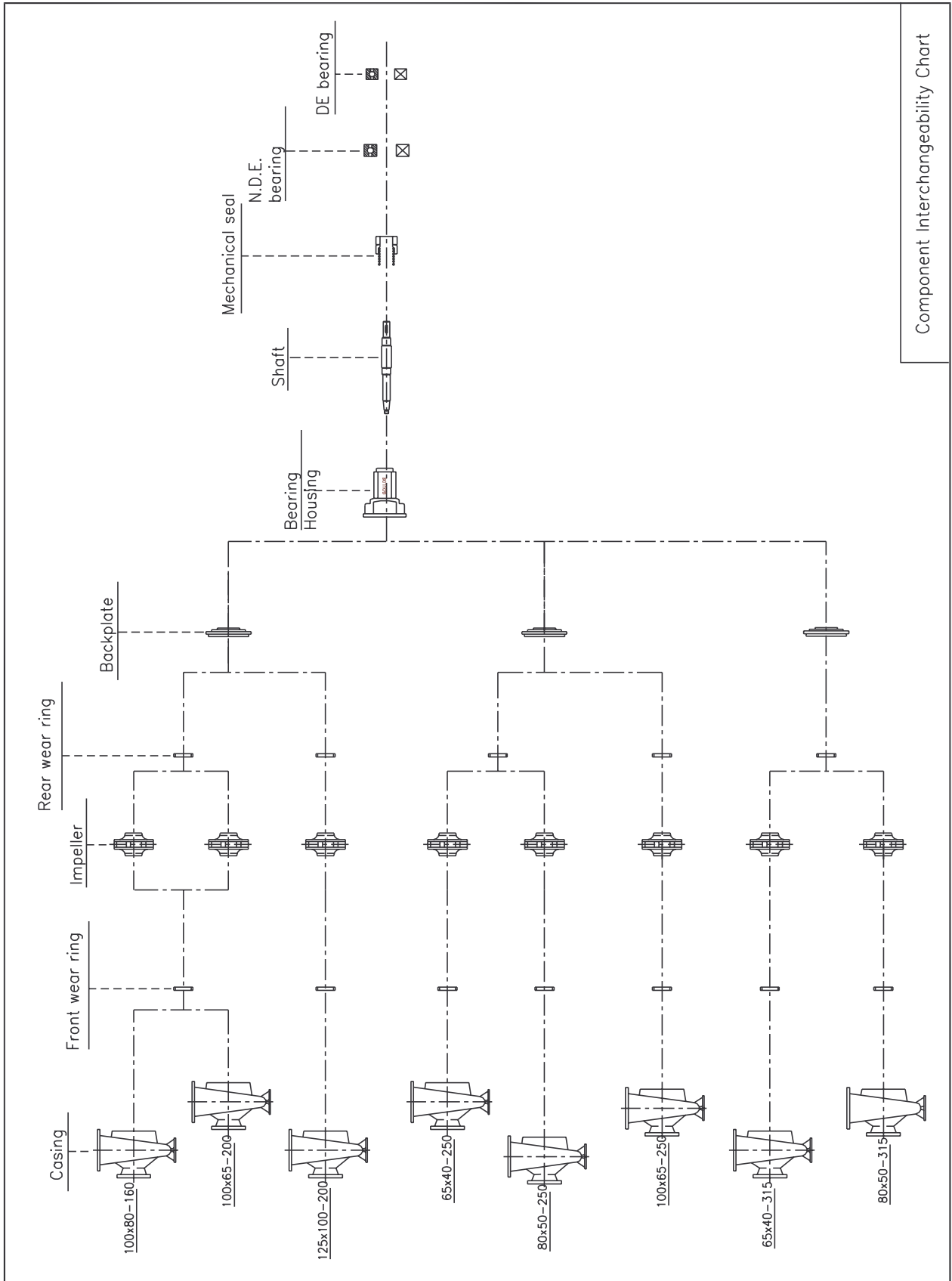

Goolds GIS Series

ISO End Suction Centrifugal Pump - Frame Mount Shaft Module #3

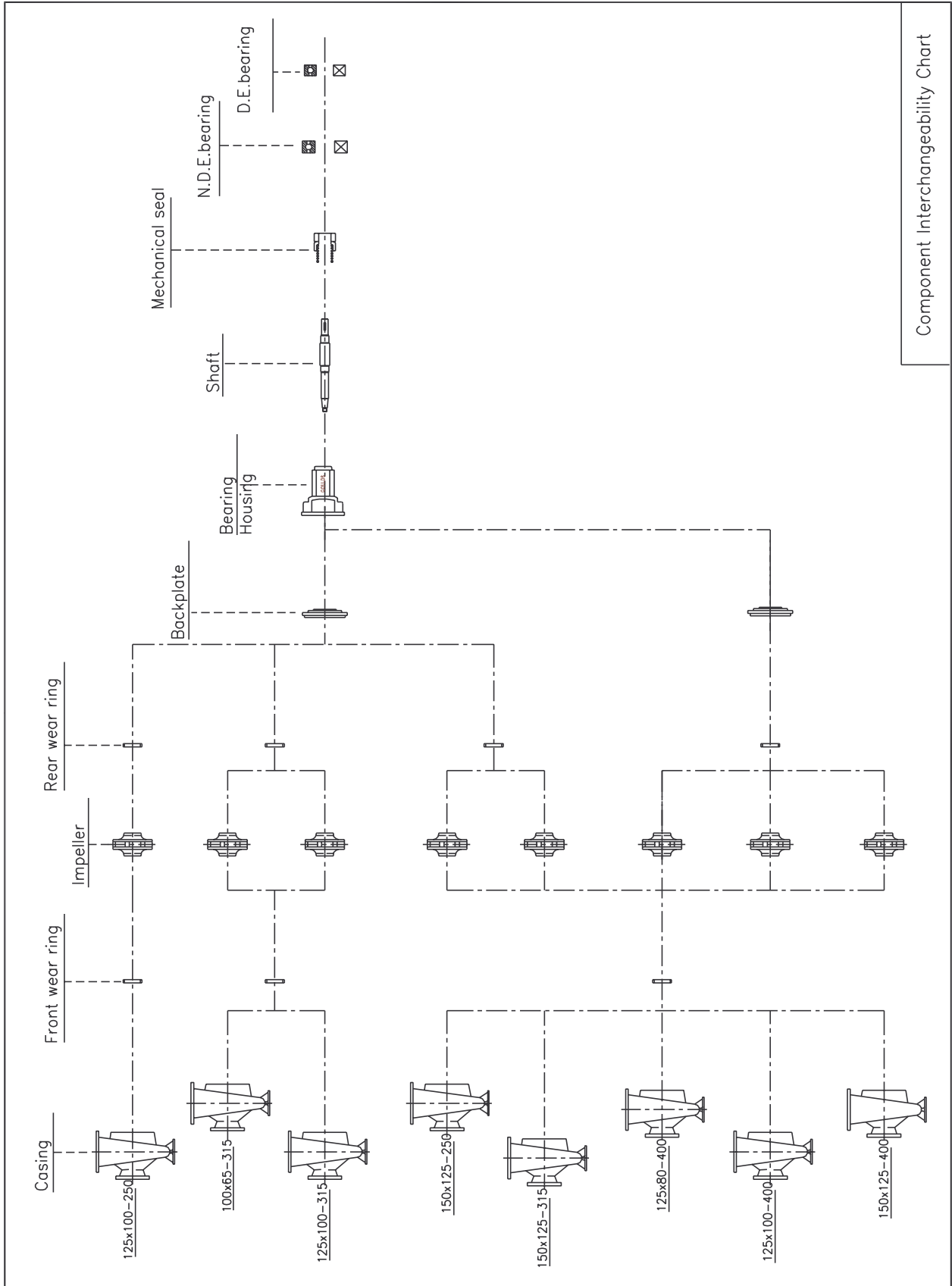

Component Interchangeability Chart

Goolds GIS Series

ISO End Suction Centrifugal Pump - Frame Mount Shaft Module #4

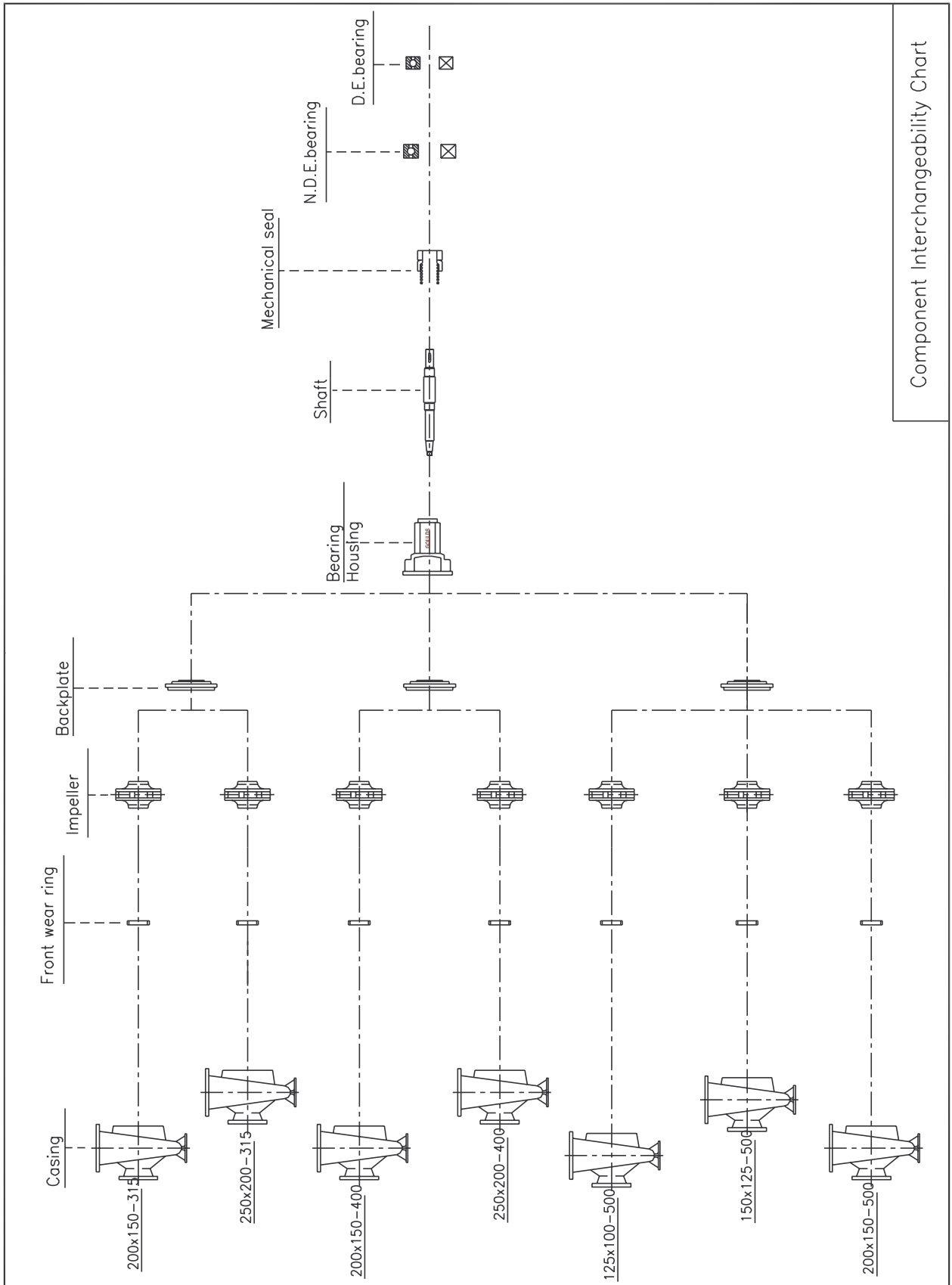

Component Interchangeability Chart

Goolds GIS Series

ISO End Suction Centrifugal Pump - Stub Shaft Pumpset Dimensions (2 Pole)

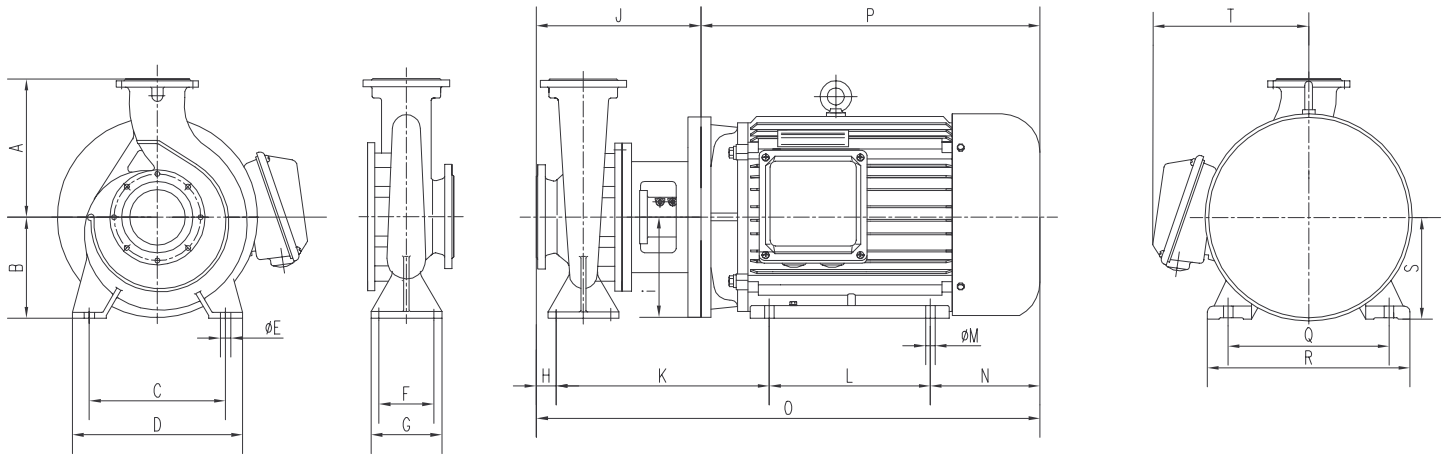

PUMP	Shaft Module	Dimensions								kW	Motor Frame	Dimensions										Weight excluding motor (kg)	Weight including motor (kg)		
		A	B	C	D	E	F	G	H			I	J	K	L	M	N	O	P	Q	R			S	T
50x32-160	1	160	132	190	240	14	70	100	45	3	100L	125	248	266	140	12	118	569	321	160	188	100	165	32	63
										4	112M	125	248	273	140	12	128	586	338	190	220	112	190	32	78
										5.5	132S	150	268	312	140	12	150	647	379	216	248	132	218	35	97
50x32-200	1	180	160	190	240	14	70	100	45	5.5	132S	150	268	312	140	12	150	647	379	216	248	132	218	44	106
										7.5	132S	150	268	312	140	12	150	647	379	216	248	132	218	44	106
										11	160M	175	298	361	210	14.5	174	790	492	254	308	160	256	48	148
65x50-160	1	160	132	190	240	14	70	100	45	4	112M	125	245	270	140	12	128	583	338	190	220	112	190	35	81
										5.5	132S	150	267	311	140	12	150	646	379	216	248	132	218	38	100
										7.5	132S	150	267	311	140	12	150	646	379	216	248	132	218	38	100
65x40-200	1	180	160	212	265	14	70	100	65	7.5	132S	150	288	377	140	12	150	667	379	216	248	132	218	46	108
										11	160M	175	318	426	210	14.5	174	810	492	254	308	160	256	49	149
										15	160M	175	318	426	210	14.5	174	810	492	254	308	160	256	49	158
65x40-250	2	225	180	190	320	14	95	125	52.5	11	160M	175	326	382	210	14.5	174	818	492	254	308	160	256	69	169
										15	160M	175	326	382	210	14.5	174	818	492	254	308	160	256	69	178
										18.5	160L	175	326	382	254	14.5	174	862	536	254	308	160	256	69	200
										22	180M	175	326	395	241	14.5	200	888	562	279	350	180	276	71	246
65x40-315	2	250	200	212	345	14	95	125	77.5	30	200L	200	351	407	305	18.5	222	1011	660	318	385	200	292	84	329
										37	200L	200	351	407	305	18.5	222	1011	660	318	385	200	292	84	344
										45	225S	225	381	453	286	18.5	280	1096	715	356	436	225	366	88	473
										5.5	132S	150	285	309	140	12	150	664	379	216	248	132	218	44	106
80x65-160	1	180	160	212	265	14	70	100	65	7.5	132S	150	285	309	140	12	150	664	379	216	248	132	218	44	112
										11	160M	175	323	366	210	14.5	174	815	492	254	308	160	256	48	148
										15	160M	175	323	366	210	14.5	174	815	492	254	308	160	256	48	157
										11	160M	175	318	361	210	14.5	174	810	492	254	308	160	256	49	149
80x50-200	1	200	160	212	265	14	70	100	65	15	160M	175	318	361	210	14.5	174	810	492	254	308	160	256	49	158
										18.5	160L	175	318	361	254	14.5	174	854	536	254	308	160	256	49	180
										22	180M	175	318	374	241	14.5	200	880	562	279	350	180	276	50	225
										18.5	160L	175	352	383	254	14.5	174	888	536	254	308	160	256	73	204
80x50-250	2	225	180	212	320	14	95	125	77.5	22	180M	175	352	396	241	14.5	200	914	562	279	350	180	276	74	249
										30	200L	200	352	408	305	18.5	222	1012	660	318	385	200	292	76	321
										37	200L	200	352	408	305	18.5	222	1012	660	318	385	200	292	76	336
										45	225S	225	352	424	286	18.5	280	1067	715	356	436	225	366	79	464
80x50-315	2	280	225	212	345	14	95	125	77.5	30	200L	200	351	407	305	18.5	222	1011	660	318	385	200	292	88	333
										37	200L	200	351	407	305	18.5	222	1011	660	318	385	200	292	88	348
										45	225S	225	381	453	286	18.5	280	1096	715	356	436	225	366	91	476
										55	250S	275	381	472	311	24	312	1172	791	406	506	250	366	96	546
100x80-160	2	200	160	190	280	14	95	125	52.5	75	250S	275	381	472	311	24	312	1172	791	406	506	250	366	96	566
										11	160M	175	326	382	210	14.5	174	818	492	254	308	160	256	66	166
										15	160M	175	326	382	210	14.5	174	818	492	254	308	160	256	66	175
										18.5	160L	175	326	382	254	14.5	174	862	536	254	308	160	256	66	197

- Remarks**
1. Standard flange drilling to AS 2129-1982 Table "E"
 2. Other drilling options available on request
 3. Dimensions in mm
 4. Motor dimensions and data may vary dependent on motor type

Goulds GIS Series

ISO End Suction Centrifugal Pump - Stub Shaft Pumpset Dimensions (2 Pole)

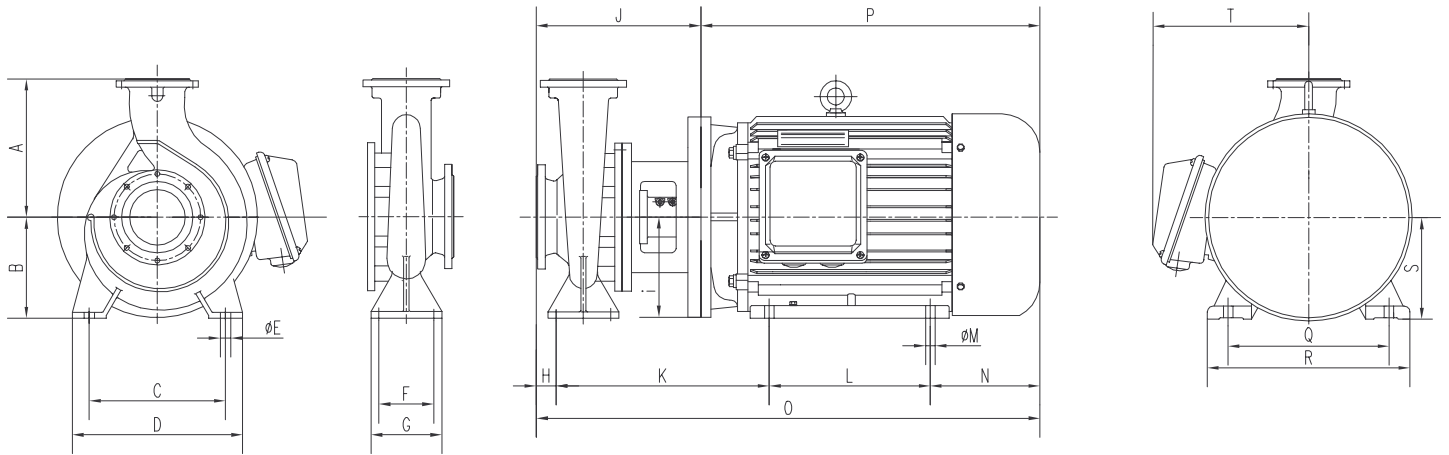

PUMP	Shaft Module	Dimensions								kW	Motor Frame	Dimensions										Weight excluding motor (kg)	Weight including motor (kg)		
		A	B	C	D	E	F	G	H			I	J	K	L	M	N	O	P	Q	R			S	T
100x65-200	2	225	180	190	320	14	95	125	52.5	15	160M	175	327	383	210	14.5	174	819	492	254	308	160	256	67	176
										18.5	160L	175	327	383	254	14.5	174	863	536	254	308	160	256	67	198
										22	180M	175	327	396	241	14.5	200	889	562	279	350	180	276	68	243
										30	200L	200	327	408	305	18.5	222	987	660	318	385	200	292	70	315
100x65-250	2	250	200	212	360	18	120	160	65	30	200L	200	352	420	305	18.5	222	1012	660	318	385	200	292	71	316
										37	200L	200	352	420	305	18.5	222	1012	660	318	385	200	292	71	331
										45	225S	225	352	436	286	18.5	280	1067	715	356	436	225	366	75	460
										55	250S	275	382	485	311	24	312	1173	791	406	506	250	366	82	532
100x65-315	3	280	225	315	400	18	120	160	65	55	250S	275	382	485	311	24	312	1173	791	406	506	250	366	82	552
										75	250S	275	401	504	311	24	312	1192	791	406	506	250	366	124	574
										75	250S	275	401	504	311	24	312	1192	791	406	506	250	366	124	594
										90	280S	275	401	526	368	24	350	1309	908	457	557	280	488	130	835
125x100-200	2	280	200	212	360	18	120	160	65	110	280S	275	401	526	368	24	350	1309	908	457	557	280	488	130	870
										22	180M	175	352	408	241	14.5	200	914	562	279	350	180	276	78	253
										30	200L	200	352	420	305	18.5	222	1012	660	318	385	200	292	80	325
										37	200L	200	352	420	305	18.5	222	1012	660	318	385	200	292	80	340
125x100-250	3	280	225	315	400	18	120	160	80	45	225S	225	352	436	286	18.5	280	1067	715	356	436	225	366	85	470
										55	250S	275	382	485	311	24	312	1173	791	406	506	250	366	94	544
										75	250S	275	382	485	311	24	312	1173	791	406	506	250	366	94	564
										55	250S	275	416	504	311	24	312	1207	791	406	506	250	366	127	577
125x100-315	3	315	250	315	400	18	120	160	80	75	250S	275	416	504	311	24	312	1207	791	406	506	250	366	127	597
										90	280S	275	416	526	368	24	350	1324	908	457	557	280	488	130	835
										110	280S	275	416	526	368	24	350	1324	908	457	557	280	488	130	870
										90	280S	275	416	526	368	24	350	1324	908	457	557	280	488	144	849
125x100-315	3	315	250	315	400	18	120	160	80	110	280S	275	416	526	368	24	350	1324	908	457	557	280	488	144	884

- Remarks**
1. Standard flange drilling to AS 2129-1982 Table "E"
 2. Other drilling options available on request
 3. Dimensions in mm
 4. Motor dimensions and data may vary dependent on motor type

Goulds GIS Series

ISO End Suction Centrifugal Pump - Stub Shaft Pumpset Dimensions (4 Pole)

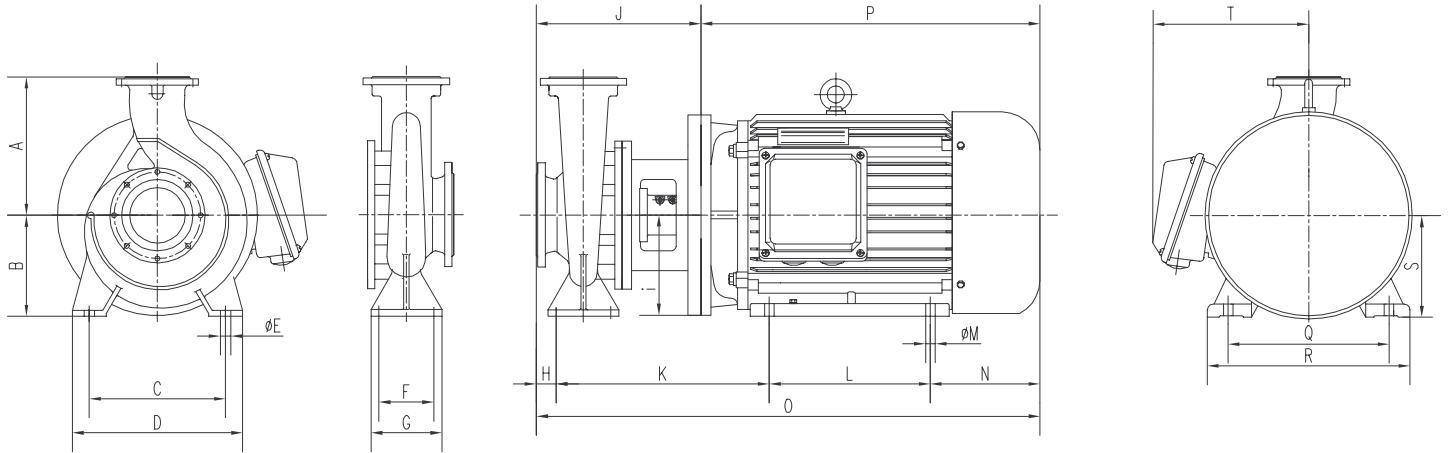

PUMP	Shaft Module	Dimensions								kW	Motor Frame	Dimensions										Weight excluding motor (kg)	Weight including motor (kg)		
		A	B	C	D	E	F	G	H			I	J	K	L	M	N	O	P	Q	R			S	T
50x32-160	1	160	132	190	240	14	70	100	45	0.75	80	100	235	240	100	10	93	478	243	125	149	80	145	31	47
										0.75	80	100	235	240	100	10	93	478	243	125	149	80	145	40	56
50x32-200	1	180	160	190	240	14	70	100	45	1.1	90S	100	235	246	100	10	104	495	260	140	164	90	155	41	63.5
										2.2	100L	125	235	253	140	12	118	556	321	160	188	100	165	41	74
65x50-160	1	160	132	190	240	14	70	100	45	0.75	80	100	233	238	100	10	93	476	243	125	149	80	145	33	49
										1.1	90S	100	243	254	100	10	104	503	260	140	164	90	155	34	56.5
65x40-200	1	180	160	212	265	14	70	100	65	1.1	90S	100	255	246	100	10	104	515	260	140	164	90	155	42	64.5
										1.5	90L	100	255	246	125	10	104	540	285	140	164	90	155	42	66
65x40-250	2	225	180	190	320	14	95	125	52.5	2.2	100L	125	262	260	140	12	118	583	321	160	188	100	165	44	77
										1.1	90S	100	259	263	100	10	104	519	260	140	164	90	155	63	85.5
65x40x315	2	250	200	212	345	14	95	125	77.5	1.5	90L	100	259	263	125	10	104	544	285	140	164	90	155	63	87
										2.2	100L	125	266	277	140	12	118	587	321	160	188	100	165	64	97
80x65-160	1	180	160	212	265	14	70	100	65	1.1	90S	100	255	246	100	10	104	515	260	140	164	90	155	41	63.5
										1.5	90L	100	255	246	125	10	104	540	285	140	164	90	155	41	65
80x50-200	1	200	160	212	265	14	70	100	65	2.2	100L	125	262	260	140	12	118	583	321	160	188	100	165	46	79
										3	100L	125	262	260	140	12	118	583	321	160	188	100	165	46	83
80x50-250	2	225	180	212	320	14	95	125	77.5	3	100L	125	291	277	140	12	118	612	321	160	188	100	165	66	103
										4	112M	125	291	284	140	12	128	629	338	190	220	112	190	67	116
80x50-315	2	280	225	212	345	14	95	125	77.5	5.5	132S	150	311	323	140	12	150	690	379	216	248	132	218	69	132
										4	112M	125	291	284	140	12	128	629	338	190	220	112	190	80	129
100x80-160	2	200	160	190	280	14	95	125	52.5	7.5	132M	150	311	323	178	12	150	728	417	216	248	132	218	83	154
										1.1	90S	100	259	263	100	10	104	519	260	140	164	90	155	62	84.5
100x80-200	2	200	160	190	280	14	95	125	52.5	1.5	90L	100	259	263	125	10	104	544	285	140	164	90	155	62	86
										2.2	100L	125	266	277	140	12	118	587	321	160	188	100	165	63	96
100x65-200	2	225	180	190	320	14	95	125	52.5	3	100L	125	266	277	140	12	118	587	321	160	188	100	165	63	100
										4	112M	125	266	284	140	12	128	604	338	190	220	112	190	65	114
100x65-200	2	225	180	190	320	14	95	125	52.5	2.2	100L	125	266	277	140	12	118	587	321	160	188	100	165	63	96
										3	100L	125	266	277	140	12	118	587	321	160	188	100	165	63	100
100x65-200	2	225	180	190	320	14	95	125	52.5	4	112M	125	316	334	140	12	128	654	338	190	220	112	190	64	113
										5.5	132S	150	286	323	140	12	150	665	379	216	248	132	218	65	128

- Remarks**
- Standard flange drilling to AS 2129-1982 Table "E"
 - Other drilling options available on request
 - Dimensions in mm
 - Motor dimensions and data may vary dependent on motor type

Goulds GIS Series

ISO End Suction Centrifugal Pump - Stub Shaft Pumpset Dimensions (4 Pole)

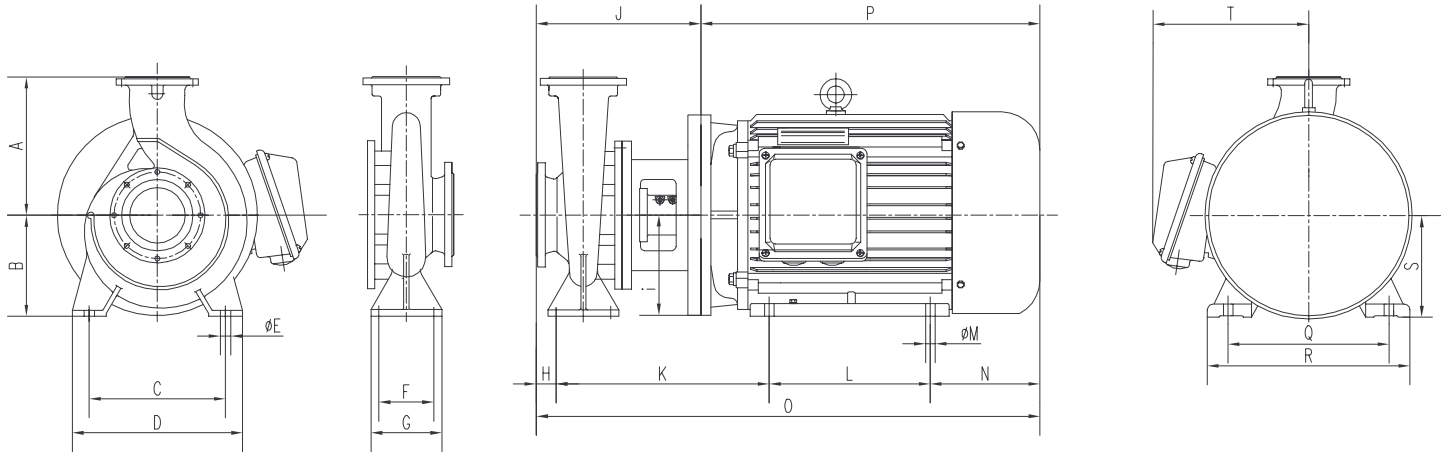

PUMP	Shaft Module	Dimensions								kW	Motor Frame	Dimensions										Weight excluding motor (kg)	Weight including motor (kg)		
		A	B	C	D	E	F	G	H			I	J	K	L	M	N	O	P	Q	R			S	T
100x65-250	2	250	200	212	360	18	120	160	65	3	100L	125	291	289	140	12	118	612	321	160	188	100	165	66	103
										4	112M	125	291	296	140	12	128	629	338	190	220	112	190	66	115
										5.5	132S	150	311	335	140	12	150	690	379	216	248	132	218	68	131
										7.5	132M	150	311	335	178	12	150	728	417	216	248	132	218	68	139
100x65-315	3	280	225	315	400	18	120	160	65	5.5	132S	150	330	354	140	12	150	709	379	216	248	132	218	110	173
										7.5	132M	150	330	354	178	12	150	747	417	216	248	132	218	110	181
										11	160M	175	366	409	210	14.5	174	858	492	254	308	160	256	115	225
										15	160L	175	366	409	254	14.5	174	902	536	254	308	160	256	115	236
125x100-200	2	280	200	212	360	18	120	160	65	3	100L	125	291	289	140	12	118	612	321	160	188	100	165	73	110
										4	112M	125	291	296	140	12	128	629	338	190	220	112	190	74	123
										5.5	132S	150	311	335	140	12	150	690	379	216	248	132	218	76	139
										7.5	132M	150	311	335	178	12	150	728	417	216	248	132	218	76	147
125x100-250	3	280	225	315	400	18	120	160	80	11	160M	175	381	409	210	14.5	174	873	492	254	308	160	256	123	233
										15	160L	175	381	409	254	14.5	174	917	536	254	308	160	256	123	244
										18.5	180M	175	381	422	241	14.5	200	943	562	279	350	180	276	125	290
										22	180L	175	381	422	279	14.5	200	981	600	279	350	180	276	125	310
125x100-315	3	315	250	315	400	18	120	160	80	30	200L	200	381	434	305	18.5	222	1041	660	318	385	200	292	126	366
										11	160M	175	381	409	210	14.5	174	873	492	254	308	160	256	129	239
										15	160L	175	381	409	254	14.5	174	917	536	254	308	160	256	129	250
										18.5	180M	175	381	422	241	14.5	200	943	562	279	350	180	276	132	297
125x80-400	3	355	280	355	435	18	160	120	65	22	180L	175	381	422	279	14.5	200	981	600	279	350	180	276	132	317
										11	160M	175	366	409	210	14.5	174	858	492	254	308	160	256	158	268
										15	160L	175	366	409	254	14.5	174	902	536	254	308	160	256	158	279
										18.5	180M	175	366	422	241	14.5	200	928	562	279	350	180	276	162	327
125x100-400	3	355	280	400	500	23	200	150	65	22	180L	175	366	422	279	14.5	200	966	600	279	350	180	276	162	347
										30	200L	200	366	434	305	18.5	222	1026	660	318	385	200	292	166	406
										18.5	180M	175	381	437	241	14.5	200	943	562	279	350	180	276	165	330
										22	180L	175	381	437	279	14.5	200	981	600	279	350	180	276	165	350
150x125-250	3	355	250	315	400	18	160	120	80	30	200L	200	381	449	305	18.5	222	1041	660	318	385	200	292	170	410
										37	225S	225	411	495	286	18.5	280	1126	715	356	436	225	366	176	506
										45	225S	225	411	495	286	18.5	280	1126	715	356	436	225	366	176	506
										11	160M	175	381	409	210	14.5	174	873	492	254	308	160	256	130	240
150x125-315	3	355	280	400	500	23	200	150	65	15	160L	175	381	409	254	14.5	174	917	536	254	308	160	256	130	251
										18.5	180M	175	381	422	241	14.5	200	943	562	279	350	180	276	141	306
										22	180L	175	381	422	279	14.5	200	981	600	279	350	180	276	141	326
										30	200L	200	381	434	305	18.5	222	1041	660	318	385	200	292	146	386
150x125-400	3	400	315	400	500	23	200	150	65	18.5	180M	175	381	437	241	14.5	200	943	562	279	350	180	276	145	310
										22	180L	175	381	437	279	14.5	200	981	600	279	350	180	276	145	330
										30	200L	200	381	449	305	18.5	222	1041	660	318	385	200	292	149	389
										37	225S	225	411	495	286	18.5	280	1126	715	356	436	225	366	154	484
150x125-400	3	400	315	400	500	23	200	150	65	45	225S	225	411	495	286	18.5	280	1126	715	356	436	225	366	154	484
										30	200L	200	381	449	305	18.5	222	1041	660	318	385	200	292	173	413
										37	225S	225	411	495	286	18.5	280	1126	715	356	436	225	366	178	508
										45	225S	225	411	495	286	18.5	280	1126	715	356	436	225	366	178	508

- Remarks**
- Standard flange drilling to AS 2129-1982 Table "E"
 - Other drilling options available on request
 - Dimensions in mm
 - Motor dimensions and data may vary dependent on motor type

Goulds GIS Series

ISO End Suction Centrifugal Pump - Stub Shaft Pumpset Sectional Drawing

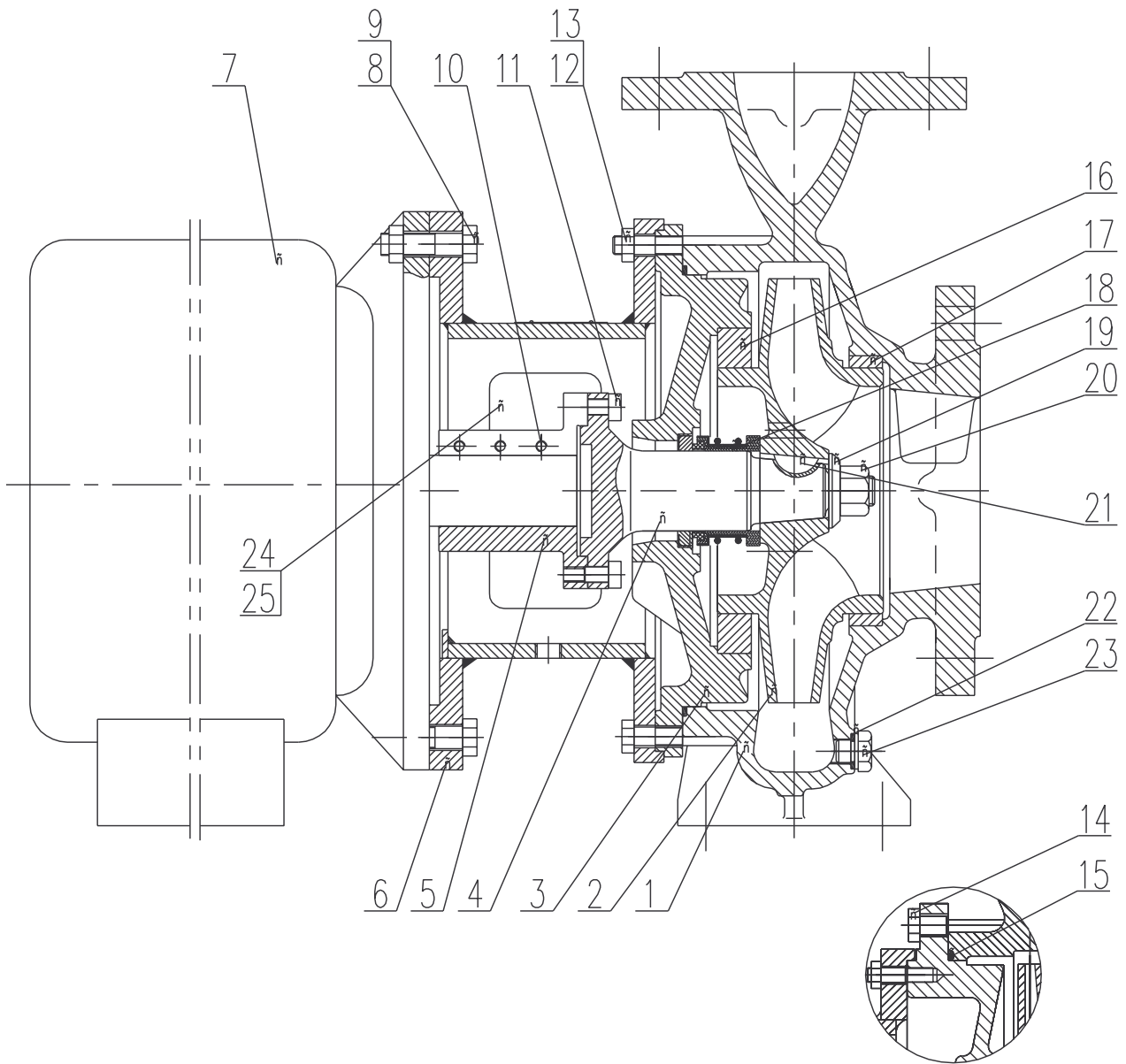

Item No.	Description	Item No.	Description	Item No.	Description
1	Pump Casing	2	Impeller	3	Backplate
4	Stub Shaft	5	Motor Clamp	6	Motor Adaptor
7	Motor	8	Nut	9	Bolt
10	Clamp Screw	11	Bolt	12	Bolt
13	Nut	14	Bolt	15	Casing O-ring
16	Rear Wear Ring	17	Front Wear Ring	18	Mechanical Seal
19	Washer	20	Impeller Nut	21	Impeller Key
22	Gasket	23	Drain Plug	24	Safeguard
25	Safeguard Setscrews				

Goolds GIS Series

ISO End Suction Centrifugal Pump - Stub Shaft Pumpset Shaft Module #1

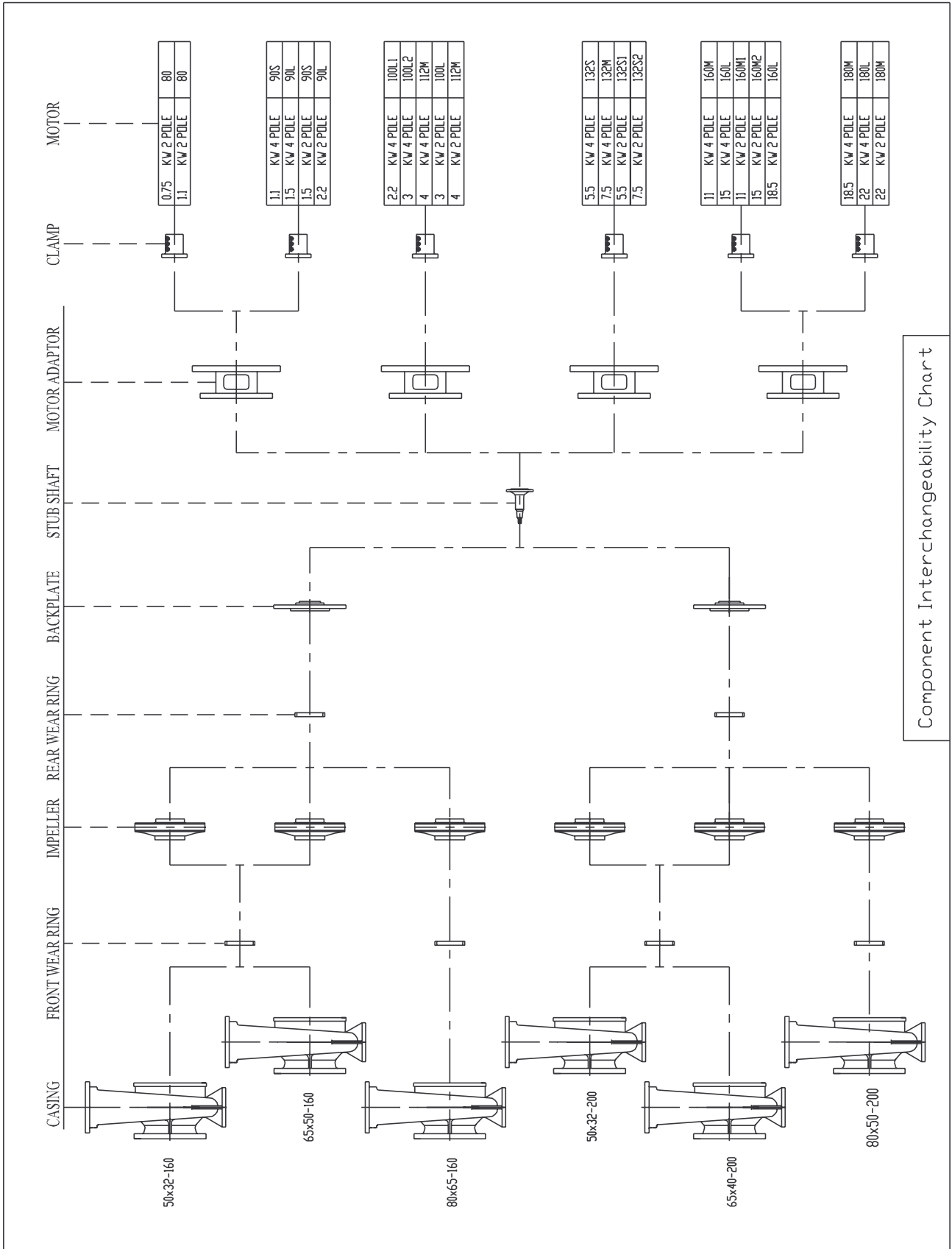

Goolds GIS Series

ISO End Suction Centrifugal Pump - Stub Shaft Pumpset Shaft Module #2

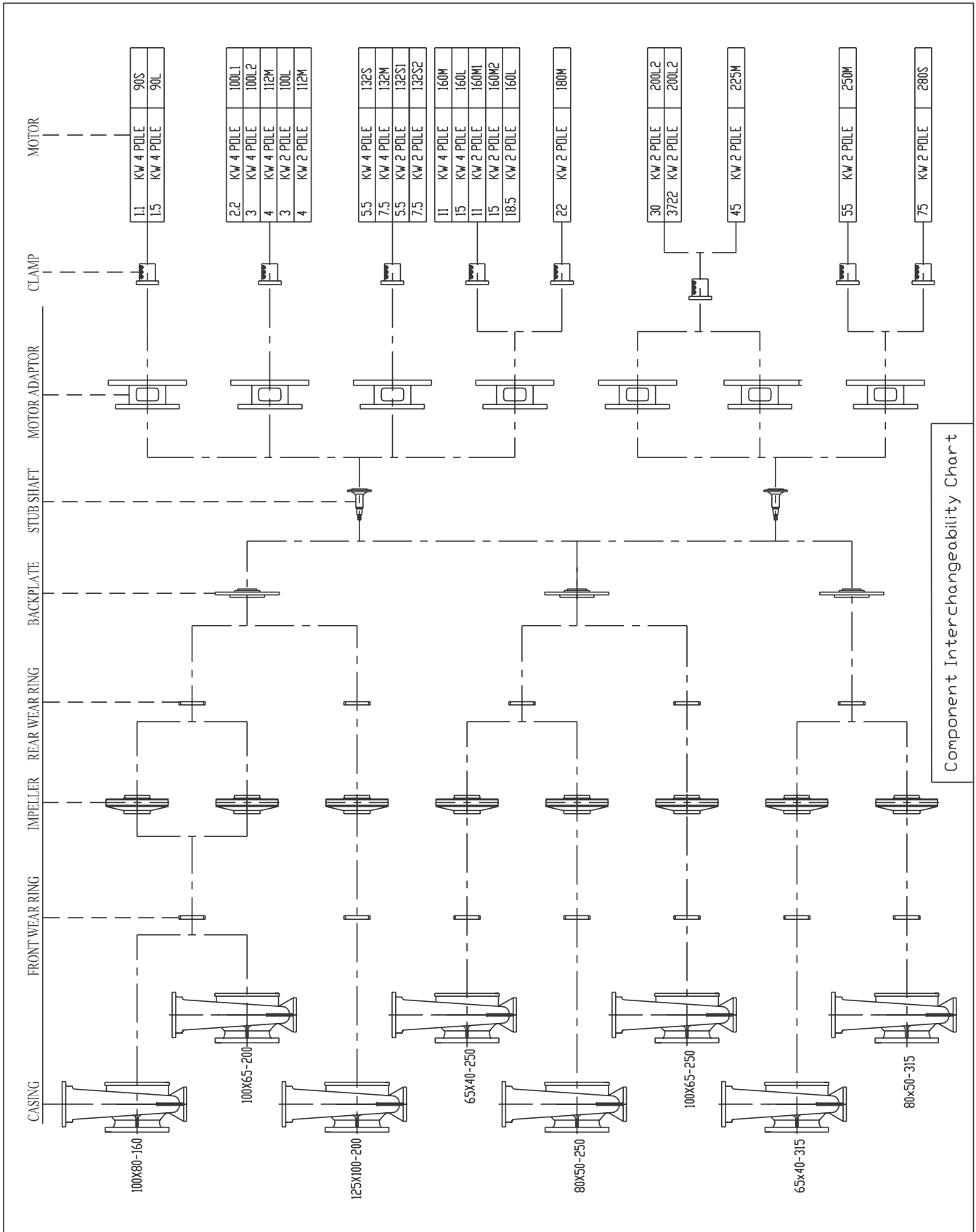

Goolds GIS Series

ISO End Suction Centrifugal Pump - Stub Shaft Pumpset Shaft Module #3

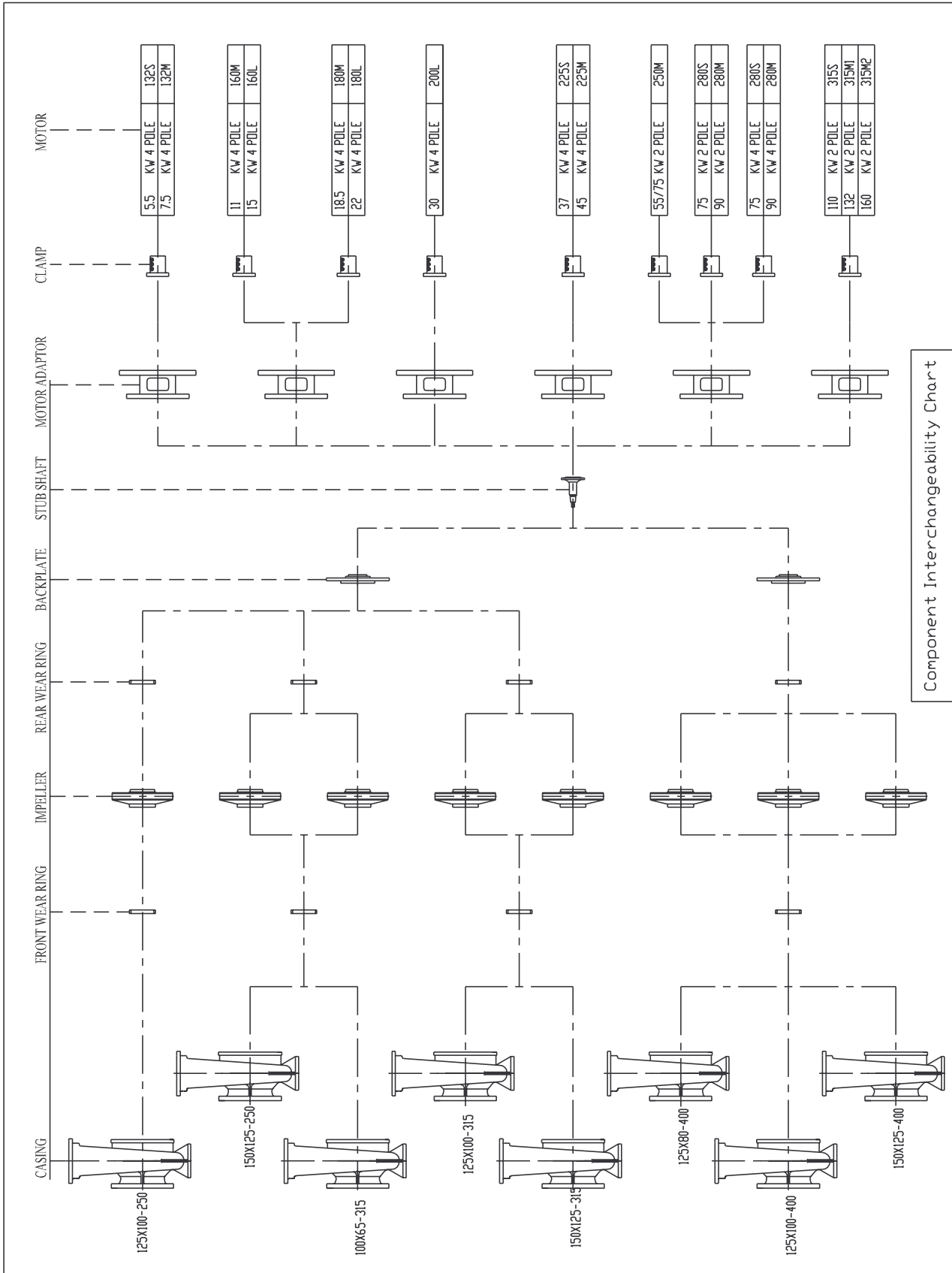

Goulds GIS Series

Materials of Construction

Standard Construction

Component	Standard Construction	Australian Standard	ASTM Standard	British Standard
Casing	Cast Iron GG25	AS1830/T260	A48-Class 35	BS1452 - Gr260
Back Plate	Cast Iron GG25	AS1830/T260	A48-Class 35	BS1452 - Gr260
Casing Wear Ring	ZF Bronze	AS1565/C90250	B427 - C90700	BS1400 PB1
Impeller	ZF Bronze	AS1565/C90250	B427 - C90700	BS1400 PB1
Impeller Key	Nickel Plated Steel			
Impeller Lock Nut	304 Stainless Steel	AS2074/H5C	A351-CF-8	BS1504-Gr304
Shaft	420 Stainless Steel	AS1444/420	A276 - Type 420	BS970 - Gr420-S37

Optional Material of Construction

Component	Optional Materials	Australian Standard	ASTM Standard	British Standard
Casing	Ductile Iron 304 Stainless Steel 316 Stainless Steel 329 Duplex SS CD4MCu	AS1831/400 AS2074/H5C AS2074/H6B	A536-84 70-50-05 A351-CF-8 A351-CF-8M A890 GR12A	BS2789-Gr500/7 BS1504-Gr304 BS1504-Gr316
Back Plate	Ductile Iron 304 Stainless Steel 316 Stainless Steel 329 Duplex SS CD4MCu	AS1831/400 AS2074/H5C AS2074/H6B	A536-84 70-50-05 A351-CF-8 A351-CF-8M A890 GR12A	BS2789-Gr500/7 BS1504-Gr304 BS1504-Gr316
Casing Wear Ring	Ductile Iron Cast Iron GG25 304 Stainless Steel 316 Stainless Steel 329 Duplex SS CD4MCu	AS1831/400 AS1830/T260 AS2074/H5C AS2074/H6B	A536-84 70-50-05 A48-Class 35 A351-CF-8 A351-CF-8M A890 GR12A	BS2789-Gr500/7 BS1452 - Gr260 BS1504-Gr304 BS1504-Gr316
Impeller	Ductile Iron Cast Iron GG25 304 Stainless Steel 316 Stainless Steel 329 Duplex SS CD4MCu	AS1831/400 AS1830/T260 AS2074/H5C AS2074/H6B	A536-84 70-50-05 A48-Class 35 A351-CF-8 A351-CF-8M A890 GR12A	BS2789-Gr500/7 BS1452 - Gr260 BS1504-Gr304 BS1504-Gr316
Impeller Lock Nut	420 Stainless Steel	AS1444/420	A276 - Type 420	BS970 - Gr420-S37
Shaft	316 Stainless Steel	AS2074/H6B	A351-CF-8M	BS1504-Gr316

Goolds GIS Series

ISO End Suction Centrifugal Pump - Technical Data (Standard Construction)

A.PUMP	UNIT	50x32-160	50x32-200	65x50-160	65x40-200
1.Discharge size	mm	32	32	50	40
2.Suction size	mm	50	50	65	65
3.Flange drilling		AS2129 - 1982 Table "E" PN16 standard, other options on request			
4.Impeller configuration		Single entry double rounded type			
5.Average Casing Thickness	mm	8	8	8	8
6.No. of stage		1	1	1	1
7.Casing configuration		Radially Split Back Pull Out			
* 8.Bare Pump Weight	Kg	38	46	40	48
* 9.Gross Shipping Volume	m ³	0.0326	0.038	0.0326	0.0437
* 10.Bearing Module Size		1	1	1	1

B.IMPELLER AND ROTOR	UNIT	50x32-160	50x32-200	65x50-160	65x40-200
1.Max Impeller Diameter	mm	182	228	182	228
2.Weight of Impeller (Bronze)	Kg	5.5	6.5	5.4	8.4
3.Weight of Bearing Element	Kg	0.464	0.464	0.464	0.464
4.Wear Ring clearance dia (max)	mm	0.3054	0.3054	0.3054	0.3054
Wear Ring clearance dia (min)	mm	0.3	0.3	0.3	0.3
5.ID of Casing wear ring	mm	92	92	92	92
6.Impeller Eye Diameter	mm	57	60	70	69
7.Impeller Eye Area	cm ²	25.52	28.27	38.48	37.39
8.M of I (Max Diameter)(Bronze)	Kg.m ²	0.0149	0.0292	0.0166	0.0325

C.SHAFT AND BEARINGS	UNIT	50x32-160	50x32-200	65x50-160	65x40-200
1.Shaft diameter at Impeller	mm	25	25	25	25
* 2.Shaft diameter at coupling	mm	24	24	24	24
* 3.Bearing Centers	mm	154	154	154	154
4.1st Critical Speed	RPM	8.76x10 ⁴	8.28x10 ⁴	8.53x10 ⁴	8.04x10 ⁴
5.Bearing size drive end		NSK6306ZZ(30x72x19)			
6.Bearing size pump end		NSK6307 ZZ (35x80x21)			

D.STUFFING BOX	UNIT	50x32-160	50x32-200	65x50-160	65x40-200
1.Inside Diameter	mm	48	48	48	48
2.Depth of Box	mm	42.5	42.5	42.5	42.5
3.Mechanical seal size	mm	Φ32x42.5	Φ32x42.5	Φ32x42.5	Φ32x42.5

E.SERVICE LIMITS	UNIT	50x32-160	50x32-200	65x50-160	65x40-200
1.Max working press	Bar	16	16	16	16
2.Max Hydrotest press	Bar	24	24	24	24
3.Max Suction press	Bar	7.5	6	7.5	6
* 4.Bearing life(calculated)	hours	44385	43125	44000	42560
5.Max Temp Mech seal	deg C	100	100	100	100
6.Max Speed (Direct drive)	RPM	3600	3600	3600	3600
* 7.Max Speed (Belt drive)	RPM	2900	2900	2900	2900

* Applies to Frame Mount versions only.

Goulds GIS Series

ISO End Suction Centrifugal Pump - Technical Data (Standard Construction)

A.PUMP	UNIT	65x40-250	65x40-315	80x65-160	80x50-200
1.Discharge size	mm	40	40	65	50
2.Suction size	mm	65	65	80	80
3.Flange drilling		AS2129 - 1982 Table "E" PN16 standard, other options on request			
4.Impeller configuration		Single entry double rounded type			
5.Average Casing Thickness	mm	9	10	9	9
6.No. of stage		1	1	1	1
7.Casing configuration		Radially Split Back Pull Out			
* 8.Bare Pump Weight	Kg	70	80	46	52
* 9.Gross Shipping Volume	m ³	0.0778	0.0971	0.0437	0.0463
* 10.Bearing Module Size		2	2	1	1

B.IMPELLER AND ROTOR	UNIT	65x40-250	65x40-315	80x65-160	80x50-200
1.Max Impeller Diameter	mm	278	342	182	228
2.Weight of Impeller (Bronze)	Kg	9.8	18	5.4	8.4
3.Weight of Bearing Element	Kg	0.829	0.829	0.464	0.464
4.Wear Ring clearance dia (max)	mm	0.3054	0.3054	0.3054	0.3054
Wear Ring clearance dia (min)	mm	0.3	0.3	0.3	0.3
5.ID of Casing wear ring	mm	105	105	105	105
6.Impeller Eye Diameter	mm	77	74	88	87
7.Impeller Eye Area	cm ²	46.57	43	60.82	59.45
8.M of I (Max Diameter)(Bronze)	Kg.m ²	0.0725	0.1901	0.0149	0.0325

C.SHAFT AND BEARINGS	UNIT	65x40-250	65x40-315	80x65-160	80x50-200
1.Shaft diameter at Impeller	mm	35	35	25	25
* 2.Shaft diameter at coupling	mm	32	32	24	24
* 3.Bearing Centers	mm	224	224	154	154
4.1st Critical Speed	RPM	5.07x10 ⁴	4.35x10 ⁴	8.76x10 ⁴	8.04x10 ⁴
5.Bearing size drive end		NSK6308 ZZ (40x90x23)		NSK6306 ZZ (30x72x19)	
6.Bearing size pump end		NSK6309 VV C3NS7 (45x100x25)		NSK6307 ZZ (35x80x21)	

D.STUFFING BOX	UNIT	65x40-250	65x40-315	80x65-160	80x50-200
1.Inside Diameter	mm	61	61	48	48
2.Depth of Box	mm	45	45	42.5	42.5
3.Mechanical seal size	mm	Φ43x45	Φ43x45	Φ32x42.5	Φ32x42.5

E.SERVICE LIMITS	UNIT	65x40-250	65x40-315	80x65-160	80x50-200
1.Max working press	Bar	16	16	16	16
2.Max Hydrotest press	Bar	24	24	24	24
3.Max Suction press	Bar	3.5	2	7.5	6
* 4.Bearing life(calculated)	hours	39285	35670	41550	39684
5.Max Temp Mech seal	deg C	100	100	100	100
6.Max Speed (Direct drive)	RPM	3600	3000	3600	3600
* 7.Max Speed (Belt drive)	RPM	2480	1800	2900	2900

* Applies to Frame Mount versions only.

Goulds GIS Series

ISO End Suction Centrifugal Pump - Technical Data (Standard Construction)

A.PUMP	UNIT	80x50-250	80x50-315	100x80-160	100x65-200
1.Discharge size	mm	50	50	80	65
2.Suction size	mm	80	80	100	100
3.Flange drilling		AS2129 - 1982 Table "E" PN16 standard, other options on request			
4.Impeller configuration		Single entry double rounded type			
5.Average Casing Thickness	mm	9	12	9	9
6.No. of stage		1	1	1	1
7.Casing configuration		Radially Split Back Pull Out			
* 8.Bare Pump Weight	Kg	72	87	68	70
* 9.Gross Shipping Volume	m ³	0.081	0.1089	0.0605	0.0778
* 10.Bearing Module Size		2	2	2	2

B.IMPELLER AND ROTOR	UNIT	80x50-250	80x50-315	100x80-160	100x65-200
1.Max Impeller Diameter	mm	278	342	182	228
2.Weight of Impeller (Bronze)	Kg	12.5	14	7.2	10.5
3.Weight of Bearing Element	Kg	0.829	0.829	0.829	0.829
4.Wear Ring clearance dia (max)	mm	0.404	0.404	0.413	0.413
Wear Ring clearance dia (min)	mm	0.35	0.35	0.35	0.35
5.ID of Casing wear ring	mm	115	115	132	132
6.Impeller Eye Diameter	mm	86	90	112	112
7.Impeller Eye Area	cm ²	58.09	63.62	98.52	98.52
8.M of I (Max Diameter)(Bronze)	Kg.m ²	0.0734	0.1842	0.0232	0.0448

C.SHAFT AND BEARINGS	UNIT	80x50-250	80x50-315	100x80-160	100x65-200
1.Shaft diameter at Impeller	mm	35	35	35	35
* 2.Shaft diameter at coupling	mm	32	32	32	32
* 3.Bearing Centers	mm	224	224	224	224
4.1st Critical Speed	RPM	5.05x10 ⁴	4.39x10 ⁴	5.42x10 ⁴	5.17x10 ⁴
5.Bearing size drive end		NSK6308 ZZ (40x90x23)			
6.Bearing size pump end		NSK6309 ZZ (45x100x25)			

D.STUFFING BOX	UNIT	80x50-250	80x50-315	100x80-160	100x65-200
1.Inside Diameter	mm	61	61	61	61
2.Depth of Box	mm	45	45	45	45
3.Mechanical seal size	mm	Φ43x45	Φ43x45	Φ43x45	Φ43x45

E.SERVICE LIMITS	UNIT	80x50-250	80x50-315	100x80-160	100x65-200
1.Max working press	Bar	16	16	16	16
2.Max Hydrotest press	Bar	24	24	24	24
3.Max Suction press	Bar	3.5	2	7.5	6
* 4.Bearing life(calculated)	hours	36578	30867	43056	38057
5.Max Temp Mech seal	deg C	100	100	100	100
6.Max Speed (Direct drive)	RPM	3600	3000	3600	3600
* 7.Max Speed (Belt drive)	RPM	2050	2800	2850	2250

* Applies to Frame Mount versions only.

Goolds GIS Series

ISO End Suction Centrifugal Pump - Technical Data (Standard Construction)

A.PUMP	UNIT	100x65-250	100x65-315	125x80-400	125x100-200
1.Discharge size	mm	65	65	80	100
2.Suction size	mm	100	100	125	125
3.Flange drilling		AS2129 - 1982 Table "E" PN16 standard, other options on request			
4.Impeller configuration		Single entry double rounded type			
5.Average Casing Thickness	mm	10	12	15	12
6.No. of stage		1	1	1	1
7.Casing configuration		Radially Split Back Pull Out			
* 8.Bare Pump Weight	Kg	80	118	165	85
* 9.Gross Shipping Volume	m ³	0.1013	0.1324	0.181	0.108
* 10.Bearing Module Size		2	3	3	2

B.IMPELLER AND ROTOR	UNIT	100x65-250	100x65-315	125x80-400	125x100-200
1.Max Impeller Diameter	mm	278	342	438	228
2.Weight of Impeller (Bronze)	Kg	10.2	16.6	29	9.2
3.Weight of Bearing Element	Kg	0.829	1.37	1.37	0.829
4.Wear Ring clearance dia (max)	mm	0.413	0.463	0.522	0.463
Wear Ring clearance dia (min)	mm	0.35	0.4	0.45	0.4
5.ID of Casing wear ring	mm	132	160	186	160
6.Impeller Eye Diameter	mm	108	125	127	133
7.Impeller Eye Area	cm ²	91.61	122.72	126.68	138.93
8.M of I (Max Diameter)(Bronze)	Kg.m ²	0.0734	0.2047	0.6235	0.0533

C.SHAFT AND BEARINGS	UNIT	100x65-250	100x65-315	125x80-400	125x100-200
1.Shaft diameter at Impeller	mm	35	45	45	35
* 2.Shaft diameter at coupling	mm	32	42	42	32
* 3.Bearing Centers	mm	224	192	192	224
4.1st Critical Speed	RPM	5.05x10 ⁴	7.51x10 ⁴	6.24x10 ⁴	4.96x10 ⁴
5.Bearing size drive end		NSK6308 ZZ(40x90x23)	NSK6310 ZZ (50x110x27)	NSK6308 ZZ(40x90x23)	
6.Bearing size pump end		NSK6309 ZZ(45x100x25)	NSK6311 ZZ (55x120x29)	NSK6309 ZZ(45x100x25)	

D.STUFFING BOX	UNIT	100x65-250	100x65-315	125x80-400	125x100-200
1.Inside Diameter	mm	61	73	73	61
2.Depth of Box	mm	45	48	48	45
3.Mechanical seal size	mm	Φ43x45	Φ53x47.5	Φ53x47.5	Φ43x45

E.SERVICE LIMITS	UNIT	100x65-250	100x65-315	125x80-400	125x100-200
1.Max working press	Bar	16	16	16	16
2.Max Hydrotest press	Bar	24	24	24	24
3.Max Suction press	Bar	3.5	2	7	6
* 4.Bearing life(calculated)	hours	29557	18000	38150	28345
5.Max Temp Mech seal	deg C	100	100	100	100
6.Max Speed (Direct drive)	RPM	3600	3000	2350	3600
* 7.Max Speed (Belt drive)	RPM	2180	1450	1450	2060

* Applies to Frame Mount versions only.

Goulds GIS Series

ISO End Suction Centrifugal Pump - Technical Data (Standard Construction)

A.PUMP	UNIT	125x100-250	125x100-315	125x100-400	125x100-500
1.Discharge size	mm	100	100	100	100
2.Suction size	mm	125	125	125	125
3.Flange drilling		AS2129 - 1982 Table "E" PN16 standard, other options on request			
4.Impeller configuration		Single entry double rounded type			
5.Average Casing Thickness	mm	11	15	15	19
6.No. of stage		1	1	1	1
7.Casing configuration		Radially Split Back Pull Out			
* 8.Bare Pump Weight	Kg	126	135	175	313
* 9.Gross Shipping Volume	m ³	0.1354	0.1515	0.2128	0.3675
* 10.Bearing Module Size		3	3	3	4

B.IMPELLER AND ROTOR	UNIT	125x100-250	125x100-315	125x100-400	125x100-500
1.Max Impeller Diameter	mm	278	274	438	438
2.Weight of Impeller (Bronze)	Kg	15.2	19.8	29	39.5
3.Weight of Bearing Element	Kg	1.37	1.37	1.37	2.11
4.Wear Ring clearance dia (max)	mm	0.522	0.463	0.522	0.463
Wear Ring clearance dia (min)	mm	0.45	0.4	0.45	0.4
5.ID of Casing wear ring	mm	186	160	186	170
6.Impeller Eye Diameter	mm	138	137	140	158
7.Impeller Eye Area	cm ²	149.57	147.41	153.94	196.07
8.M of I (Max Diameter)(Bronze)	Kg.m ²	0.1256	0.1314	0.5995	0.8633

C.SHAFT AND BEARINGS	UNIT	125x100-250	125x100-315	125x100-400	125x100-500
1.Shaft diameter at Impeller	mm	45	45	45	53
* 2.Shaft diameter at coupling	mm	42	42	42	48
* 3.Bearing Centers	mm	192	192	192	258
4.1st Critical Speed	RPM	7.65x10 ⁴	7.51x10 ⁴	6.32x10 ⁴	4.26x10 ⁴
5.Bearing size drive end		NSK6310 ZZ (50x120x27)			NSK6313 ZZ(65x140x33)
6.Bearing size pump end		NSK6311 ZZ (55x120x29)			NSK6313 ZZ(65x140x33)

D.STUFFING BOX	UNIT	125x100-250	125x100-315	125x100-400	125x100-500
1.Inside Diameter	mm	73	73	73	80
2.Depth of Box	mm	48	48	48	52.5
3.Mechancial seal size	mm	Φ53x47.5	Φ53x47.5	Φ53x47.5	Φ60x52.5

E.SERVICE LIMITS	UNIT	125x100-250	125x100-315	125x100-400	125x100-500
1.Max working press	Bar	16	16	16	16
2.Max Hydrotest press	Bar	24	24	24	24
3.Max Suction press	Bar	3.5	2	7	4.5
* 4.Bearing life(calculated)	hours	18122	17500	35450	29450
5.Max Temp Mech seal	deg C	100	100	100	100
6.Max Speed (Direct drive)	RPM	3000	3000	2350	1800
* 7.Max Speed (Belt drive)	RPM	1620	1380	1240	1240

* Applies to Frame Mount versions only.

Goulds GIS Series

ISO End Suction Centrifugal Pump - Technical Data (Standard Construction)

A.PUMP	UNIT	150x125-250	150x125-315	150x125-400	150x125-500
1.Discharge size	mm	125	125	115	125
2.Suction size	mm	150	150	150	150
3.Flange drilling		AS2129 - 1982 Table "E" PN16 standard, other options on request			
4.Impeller configuration		Single entry double rounded type			
5.Average Casing Thickness	mm	14	15	16	20
6.No. of stage		1	1	1	1
7.Casing configuration		Radially Split Back Pull Out			
* 8.Bare Pump Weight	Kg	140	150	186	336
* 9.Gross Shipping Volume	m ³	0.1622	0.2128	0.2396	0.3675
* 10.Bearing Module Size		3	3	3	4

B.IMPELLER AND ROTOR	UNIT	150x125-250	150x125-315	150x125-400	150x125-500
1.Max Impeller Diameter	mm	278	342	438	438
2.Weight of Impeller (Bronze)	Kg	15.2	20.2	28.5	42.5
3.Weight of Bearing Element	Kg	1.37	1.37	1.37	2.11
4.Wear Ring clearance dia (max)	mm	0.522	0.522	0.522	0.522
Wear Ring clearance dia (min)	mm	0.45	0.45	0.45	0.45
5.ID of Casing wear ring	mm	186	186	186	200
6.Impeller Eye Diameter	mm	154	160	170	175
7.Impeller Eye Area	cm ²	186.27	201.06	226.98	240.53
8.M of I (Max Diameter)(Bronze)	Kg.m ²	0.1159	0.2398	0.5516	0.9592

C.SHAFT AND BEARINGS	UNIT	150x125-250	150x125-315	150x125-400	150x125-500
1.Shaft diameter at Impeller	mm	45	45	45	53
* 2.Shaft diameter at coupling	mm	42	42	42	48
* 3.Bearing Centers	mm	192	192	192	258
4.1st Critical Speed	RPM	7.81x10 ⁴	7.19x10 ⁴	6.5x10 ⁴	4.11x10 ⁴
5.Bearing size drive end		NSK6310 ZZ (50x110x27)			NSK6313 ZZ(65x140x33)
6.Bearing size pump end		NSK6311 ZZ (55x120x29)			NSK6313 ZZ(65x140x33)

D.STUFFING BOX	UNIT	150x125-250	150x125-315	150x125-400	150x125-500
1.Inside Diameter	mm	73	73	73	80
2.Depth of Box	mm	48	48	48	52.5
3.Mechanical seal size	mm	Φ53x47.5	Φ53x47.5	Φ53x47.5	Φ60x52.5

E.SERVICE LIMITS	UNIT	150x125-250	150x125-315	150x125-400	150x125-500
1.Max working press	Bar	16	16	16	16
2.Max Hydrotest press	Bar	24	24	24	24
3.Max Suction press	Bar	3.5	2	7	4.5
* 4.Bearing life(calculated)	hours	42000	39235	32000	24538
5.Max Temp Mech seal	deg C	100	100	100	100
6.Max Speed (Direct drive)	RPM	2350	2350	2350	1800
* 7.Max Speed (Belt drive)	RPM	1440	1420	1060	1060

* Applies to Frame Mount versions only.

Goolds GIS Series

ISO End Suction Centrifugal Pump - Technical Data (Standard Construction)

A.PUMP	UNIT	200x150-315	200x150-400	200x150-500	250x200-315	250x200-400
1.Discharge size	mm	150	150	150	200	200
2.Suction size	mm	200	200	200	250	250
3.Flange drilling		AS2129 - 1982 Table "E" PN16 standard, other options on request				
4.Impeller configuration		Single entry double rounded type				
5.Average Casing Thickness	mm	16	18	22	17	19
6.No. of stage		1	1	1	1	1
7.Casing configuration		Radially Split Back Pull Out				
* 8.Bare Pump Weight	Kg	222	300	382	277	340
* 9.Gross Shipping Volume	m ³	0.3264	0.3493	0.4109	0.3577	0.3998
* 10.Bearing Module Size		4	4	4	4	4

B.IMPELLER AND ROTOR	UNIT	200x150-315	200x150-400	200x150-500	250x200-315	250x200-400
1.Max Impeller Diameter	mm	342	438	547	342	438
2.Weight of Impeller (Bronze)	Kg	23.2	42	51.6	34.6	37.6
3.Weight of Bearing Element	Kg	2.11	2.11	2.11	2.11	2.11
4.Wear Ring clearance dia (max)	mm	0.572	0.572	0.572	0.581	0.581
Wear Ring clearance dia (min)	mm	0.5	0.5	0.5	0.5	0.5
5.ID of Casing wear ring	mm	235	235	235	265	265
6.Impeller Eye Diameter	mm	210	206	212	232	232
7.Impeller Eye Area	cm ²	346.36	333.29	352.99	422.73	422.73
8.M of I (Max Diameter)(Bronze)	Kg.m ²	0.2924	0.7434	1.533	0.3655	0.7554

C.SHAFT AND BEARINGS	UNIT	200x150-315	200x150-400	200x150-500	250x200-315	250x200-400
1.Shaft diameter at Impeller	mm	53	53	53	53	53
* 2.Shaft diameter at coupling	mm	48	48	48	48	48
* 3.Bearing Centers	mm	258	258	258	258	258
4.1st Critical Speed	RPM	5.01x10 ⁴	4.45x10 ⁴	4.08x10 ⁴	4.74x10 ⁴	4.43x10 ⁴
5.Bearing size drive end		NSK6313 ZZ (65x140x33)				
6.Bearing size pump end		NSK6313 ZZ (65x140x33)				

D.STUFFING BOX	UNIT	200x150-315	200x150-400	200x150-500	250x200-315	250x200-400
1.Inside Diameter	mm	80	80	80	80	80
2.Depth of Box	mm	52.5	52.5	52.5	52.5	52.5
3.Mechanical seal size	mm	Φ60x52.5	Φ60x52.5	Φ60x52.5	Φ60x52.5	Φ60x52.5

E.SERVICE LIMITS	UNIT	200x150-315	200x150-400	200x150-500	250x200-315	250x200-400
1.Max working press	Bar	16	16	16	16	16
2.Max Hydrotest press	Bar	24	24	24	24	24
3.Max Suction press	Bar	2	7	4.5	2	7
* 4.Bearing life(calculated)	hours	28588	28876	21559	27689	23120
5.Max Temp Mech seal	deg C	100	100	100	100	100
6.Max Speed (Direct drive)	RPM	1800	1800	1800	1800	1800
* 7.Max Speed (Belt drive)	RPM	1150	920	920	920	920

* Applies to Frame Mount versions only.

ITT Fluid Technology International (Aust) P/L
18 Commercial Drive, Dandenong South
Victoria 3175, Australia
Tel: (61) 3 9706 5066, Fax: (61) 3 9706 6065
Oct / 04

Goulds Pumps



ITT Industries
Engineered for life